

Basic Safety & Operational Specifications for Active Barriers

X57-653 Hazardous Area Signal Repeater for Dry Contacts or NAMUR Proximity Sensors

- ◆ Accepts Dry Contacts, Supervised Contacts, and Proximity Sensors
- ◆ Plug-in Style - Simple Installation, Commissioning, & Maintenance
- ◆ Power “ON”, Status, and Input Fault LED Indicators
- ◆ Front Panel Switch for “Norm. Energized or De-Energized” Output
- ◆ DIN Rail or Multi-barrier Surface Mount Chassis Options

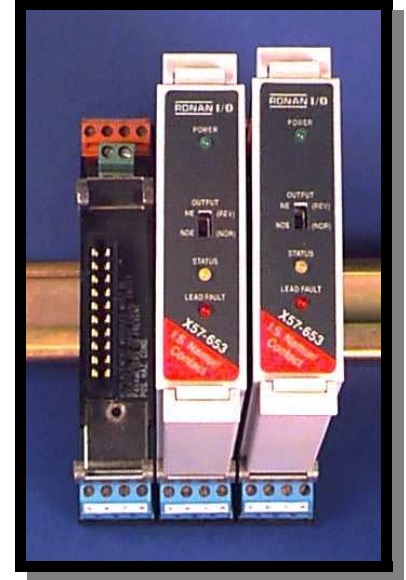

DESCRIPTION: The Ronan Model X57-653 provides an intrinsically safe interface for a switch or proximity sensor in the hazardous area. It provides a high current, Form C contact output in the safe area. Front panel LED's indicate that power is applied, the status of input signal, and input fault conditions for Namur and supervised dry contacts. Input fault monitoring can be disabled by adding a jumper across terminals 7 and 8, for standard dry contact inputs. A front panel switch selects normal or reverse action of the output relay with respect to a given input signal condition.

SPECIFICATIONS:

Type: active galvanic isolation
Chassis: plug-in single or multi-barrier chassis
Mounting: surface mount (single/multiple barrier) or single DIN rail mount
Wiring: all wiring and grounding connects to terminals on the chassis
Wire Size: up to #12 awg (1.5 mm²)
Size: 3.6”H X 0.88”W X 4.75”D (without chassis) (91.44mm X 22.35mm X 120.65 mm)
Weight: 6 oz (168 gm) (without chassis)
Power Supply: 24 VDC (21 to 35 VDC)
Power Consumption: < 1.1 watts at 24 vdc
Response Time: 10 msec.
Max. Switching Frequency: 25 Hz

Inputs: Dry/supervised contacts or NAMUR proximity sensors.
 a) Open circuit voltage: 8.5 vdc (approx.)
 b) Short circuit current: 8.5 mA (approx.)
 c) Switching points: >1.2 mA and <2.1 mA
 d) Lead Fault: X57-653’s output is normally inhibited for open or short circuit at input. Lead Fault detection can be disabled for plain dry contact inputs.
Outputs: a) SPDT relay rated 5amp/250 VAC or 5amp/30 VDC (resistive loads)
 b) Power On LED (green)
 c) Status LED (yellow)
 d) Lead Fault LED (red)
Input/Output Isolation: 2500 Vrms
Operating Temp.: -4°F to 131°F (-20°C to +55°C)
Storage Temp.: -40°F to 176°F (-40°C to +80°C)
Approvals: Class I, II, III; Div.1; Grps A-G

Specifications apply at 23 +/- 2°C (74 +/- 2°F) unless otherwise specified, and are subject to change without notice,

SAFETY PARAMETERS:				Ca (µF)			La (mH)		
for pins 7 & 8 and (5 & 6)	Voc/ Vmax/Uz	Isc (mA)	Rmin (ohms)	Groups A/B	Groups C, E	Groups D,F,G	Groups A/B	Groups C, E	Groups D,F,G
FM	10.5	11.1		2.59	7.76	20.70	267	930	1000
CSA	10.5	11.1	1000	2.59	7.76	20.70	267	930	1000
UL	Pending								
CENECLEC	Pending								

X57-653 Haz. Area Signal Repeater for Dry Contacts or NAMUR Proximity Sensors (con't)

APPLICATION:

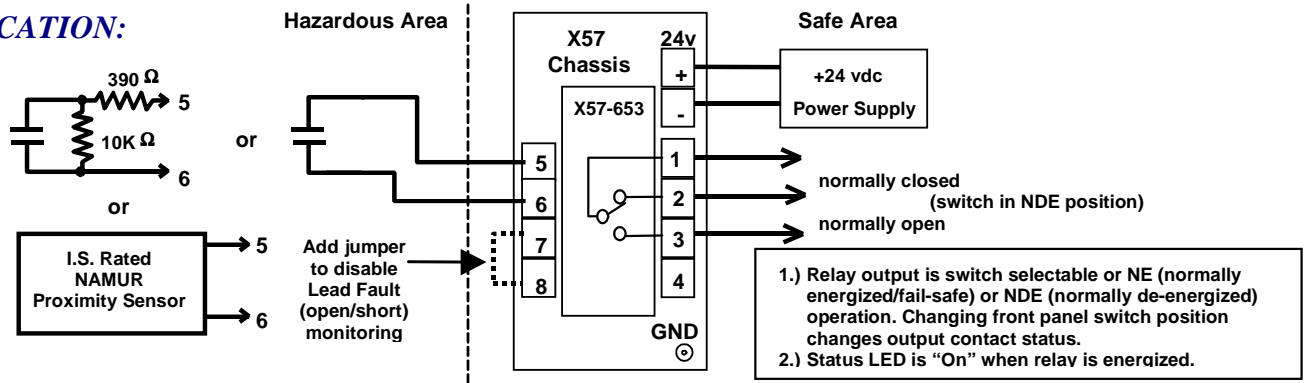

Important Note: I.S. ground is not required.

MECHANICAL DETAIL:

- A = connector protection/ alignment shroud
- B = chassis locking ears
- C = quick release tabs
- D = Power "ON" LED
- E = output option switch (NE/NDE)
- F = status LED
- G = Lead Fault LED

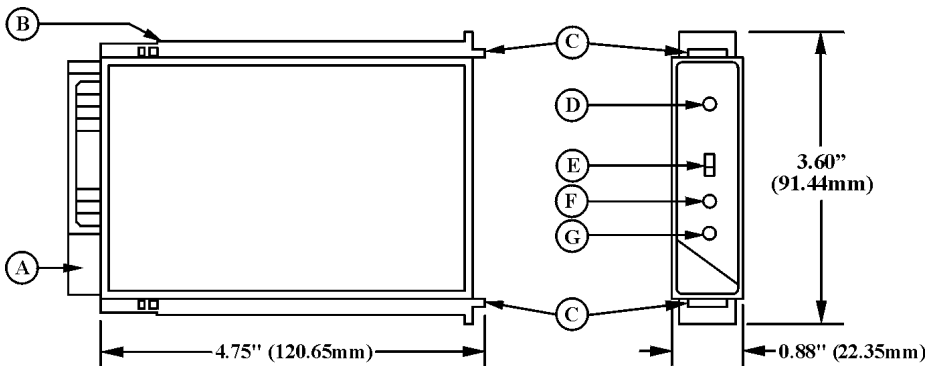

ORDERING INFORMATION:

Barriers:

X57-653Repeats the status of a dry or supervised contact or the status of an I.S. certified NAMUR proximity sensor

Chassis Options:

X57-PDIN-32 single barrier chassis for 32 mm "G" style DIN rails
 X57-PDIN-35..... single barrier chassis for 35 mm "U" style DIN rails

X57SM-1 single barrier surface mount chassis
 X57SM-1-3-4 single barrier surface mount chassis with optional ground bar and four ground clamps
 X57SM-4-(?)-(??)-(???) four (4) barrier surface mount chassis (gnd. bars & clamps optional)
 X57SM-10-(?)-(??)-(???) ten (10) barrier surface mount chassis (gnd. bars & clamps optional)
 X57SM-16-(?)-(??)-(???) sixteen barrier surface mount chassis (gnd. bars & clamps optional)
 X57SM-20-(?)-(??)-(???) twenty barrier surface mount chassis (gnd. bars & clamps optional)

? ➔ 1= optional ground bar on safe side; 2= optional gnd. bar on haz. side; 3= gnd. bars on both sides; omit if not needed
 ?? ➔ Qty of gnd. clamps on safe side gnd bar. (max qty.= 16 for SM-4, 40 for SM-10, 64 for SM-16; 80 for SM-20) or omit
 ??? ➔ Qty of gnd. clamps on haz. side gnd bar. (max qty.= 16 for SM-4, 40 for SM-10, 64 for SM-16; 80 for SM-20) or omit

Accessories:

X57-GC ground clamps
 X57-BLK blank panel for unused chassis position
 D1-32x15 32 mm X 15mm "G" style DIN rail (order by the foot)
 D2-35x7.5 35 mm X 7.5 mm "U" style DIN rail (order by the foot)

