

Basic Safety & Operational Specifications for Active Barriers

X57-650 Dual Channel - Hazardous Area Contact Status Repeater

- ◆ Accepts Dry Contacts, Supervised Contacts, and Proximity Sensors
- ◆ Plug-in Style - Simple Installation, Commissioning, and Maintenance
- ◆ 2 Independent Channels - Conserve Chassis & Panel Space
- ◆ Switch selectable Input and Output Configurations.
- ◆ DIN Rail or Multi-barrier Surface Mount Chassis Options

DESCRIPTION: The Model X57-650 Intrinsically Safe Contact Repeater accepts inputs from dry contacts, relays or proximity switches. Ronan's X57-650 provides two operating channels with independent, isolated relay contact outputs in the safe area. The X57-650 Contact Repeater provides maximum flexibility to the user as all options are field configurable. Access to the option determining dip switch and plug-in jumpers is via a field removable side panel. Each channel has independently field configurable options as follows: 1. Contact or proximity detector input. 2. Normally open or normally closed input. 3. Normally de-energized or normally energized Output. 4. Normally open or closed output contacts.



SPECIFICATIONS:

Type: active galvanic isolation
Chassis: plug-in single or multi-barrier chassis
Mounting: surface mount (single/multiple barrier) or single DIN rail mount
Wiring: all wiring connects to terminals on the chassis
Wire Size: up to #12 awg (1.5 mm²)
Size: 3.6"H X 0.88"W X 4.75"D (without chassis) (91.44mm X 22.35mm X 120.65 mm)
Weight: 6 oz (168 gm) (without chassis)
Power Supply: 24 VDC (21.6 to 26.4 VDC)
Power Consumption: < 2.3 watts at 24 vdc
Response Time: 10 msec.

Inputs: Dry contacts, supervised contacts (see Application diagram on next page), or NAMUR proximity sensors.
 a) Open circuit voltage: 8.5 vdc (approx.)
 b) Short circuit current: 9.2mA (approx.)
 c) Switching points: >1.2 mA and <2.1 mA
Outputs: a) SPST relay - contacts rated 2.0 amp at 24vdc or 0.5 amp at 120 VAC (resistive loads)
 b) ch A status LED (red)
 c) ch B status LED (red)
Input/Output Isolation: 2500 Vrms
Operating Temp.: -4°F to 131°F (-20°C to +55°C)
Storage Temp.: -40°F to 176°F (-40°C to +80°C)
Approvals: Class I, II, III; Div.1; Grps A-G

Specifications apply at 23 +/- 2°C (74 +/- 2°F) unless otherwise specified, and are subject to change without notice,

SAFETY PARAMETERS:				Ca (μF)			La (mH)		
	Voc/ Vmax/Uz	Isc (mA)	Rmin (ohms)	Groups A/B	Groups C, E	Groups D,F,G	Groups A/B	Groups C, E	Groups D,F,G
FM	10.5	11.1		2.59	7.76	20.70	267	930	1000
CSA	10.5		820	Approved					
UL	Pending								
CENELEC	See Data Sheet "X57EN-650" for CENELEC approved equivalent barrier.								

X57-650 Dual Channel - Hazardous Area Contact Status Repeater (con't)

APPLICATION:

Supervised contacts are similar to NAMUR sensors in that the On/Off states are represented by a change in resistance and that results in a change of current flow in the loop.

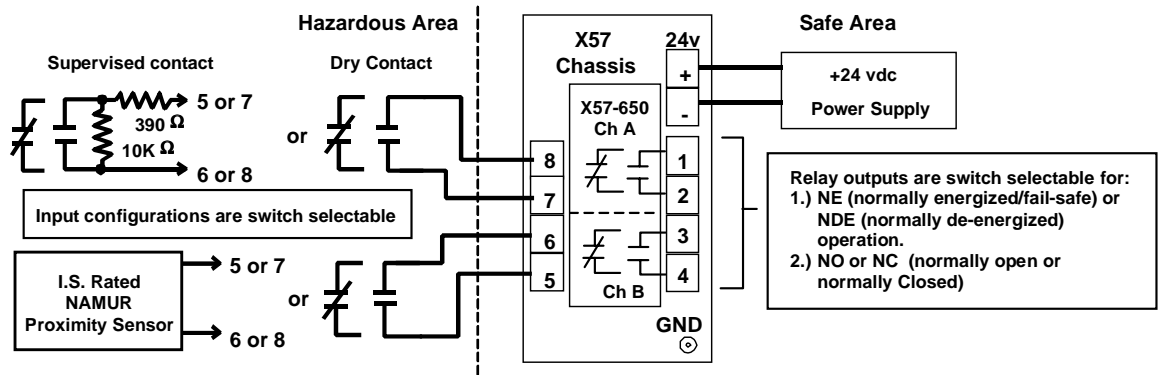

Important Notes: 1.) I.S. ground is not required. 2.) Use NAMUR settings for supervised contact inputs.

MECHANICAL DETAIL:

A = connector protection/ alignment shroud
 B = chassis locking ears
 C = quick release tabs
 D = Ch A status (red for alarm)
 E = Ch B status (red for alarm)
 F = configuration Dip switches
 G = ChA & ChB input type jumper

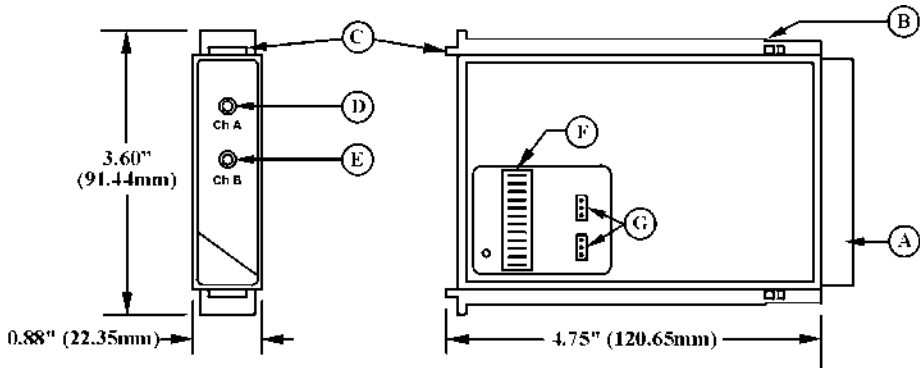

ORDERING INFORMATION:

Barriers:

X57-650Repeats status of a dry or supervised contact or the status of an I.S. certified NAMUR proximity sensor

Chassis Options:

X57-PDIN-32 single barrier chassis for 32 mm "G" style DIN rails
 X57-PDIN-35..... single barrier chassis for 35 mm "U" style DIN rails

X57SM-1 single barrier surface mount chassis
 X57SM-1-3-4 single barrier surface mount chassis with optional ground bar and four ground clamps
 X57SM-4-(?)-(??)-(???) four (4) barrier surface mount chassis (gnd. bars & clamps optional)
 X57SM-10-(?)-(??)-(???) ten (10) barrier surface mount chassis (gnd. bars & clamps optional)
 X57SM-16-(?)-(??)-(???) sixteen barrier surface mount chassis (gnd. bars & clamps optional)
 X57SM-20-(?)-(??)-(???) twenty barrier surface mount chassis (gnd. bars & clamps optional)

?➔ 1= optional ground bar on safe side; 2= optional gnd. bar on haz. side; 3= gnd. bars on both sides; omit if not needed
 ??➔ Qty of gnd. clamps on safe side gnd bar. (max qty.= 16 for SM-4, 40 for SM-10, 64 for SM-16; 80 for SM-20) or omit
 ??? ➔ Qty of gnd. clamps on haz. side gnd bar. (max qty.= 16 for SM-4, 40 for SM-10, 64 for SM-16; 80 for SM-20) or omit

Accessories:

X57-GC ground clamps
 X57-BLK blank panel for unused chassis position
 D1-32x15 32 mm X 15mm "G" style DIN rail (order by the foot)
 D2-35x7.5 35 mm X 7.5 mm "U" style DIN rail (order by the foot)

