

X19N

SINGLE-POINT ANNUNCIATOR



Standard X19N Model

These self-contained alarm systems provide complete annunciation capability for NEMA 4 or 12 applications. Each unit contains the necessary logic, light indicator and pushbutton switch for single point monitoring of Normally Open or Normally Closed field contacts. Complete logic circuitry provides standard "A" alarm sequence with flashing light and horn on alarm, steady light-silent horn after acknowledgement, and light out-horn silent when trouble contacts return to normal.

The isolated SPDT auxiliary contacts may be used with other alarm systems or as electrical interlocks. The design allows for easy field wiring and startup by use of a removable submodule. This submodule contains the NO/NC Field Contact Switch, the Lock/Non-Lock feature for momentary alarms, fuse holder, and the Power Miser Alarm Module. A single pushbutton switch is used for both silence and lamp test functions.

Submodule
close up

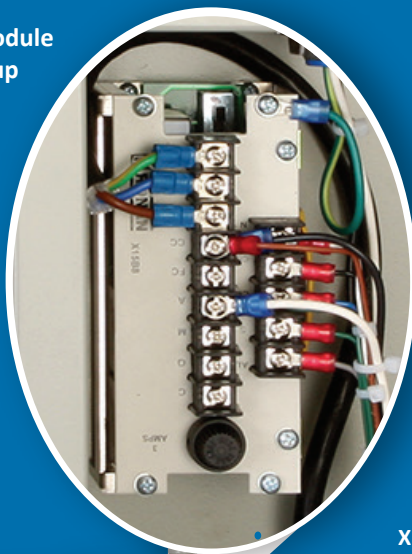

FEATURES:

- Removable submodule for maximum field wiring access
- Power Miser alarm module - reduced power consumption
- Selectable Lock/Non-lock features for momentary alarms
- Isolated contacts for use with other alarm systems or as interlock
- Selectable NO/NC field contacts
- Replaceable flasher
- Fuse protected circuitry
- Standard voltage - 115 VAC (other voltages available)
- Additional options include: sonalert, horn and/or beacon

X19N with
SonaAlert

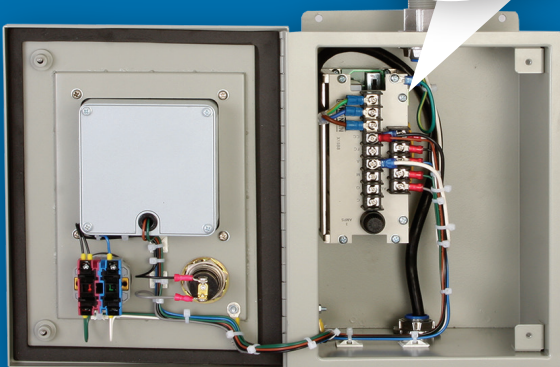

X19N with
X36 Horn
and flashing
beacon.



Dimensional Information

Front View

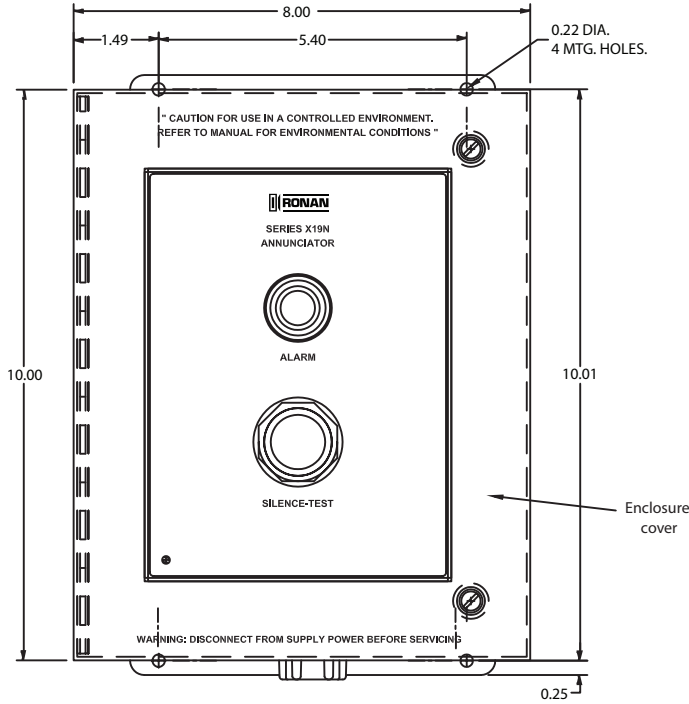

Side View

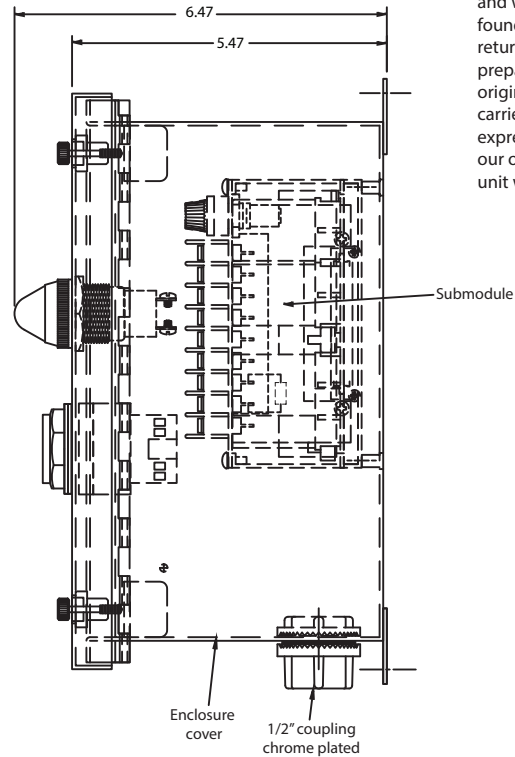

Warranty: Ronan warrants equipment of its own manufacture to be free from defects in material and workmanship, under normal conditions of use and service, and will replace any component found to be defective, on its return, transportation charges prepaid, within one year of its original purchase. This warranty carries no liability, either expressed or implied, beyond our obligations to replace the unit which carries the warranty.

Note: For dimensional drawings and wiring diagram of X19N with Horn and Beacon, please see separate sales brochure.

Wiring Diagram for Standard X19N Model

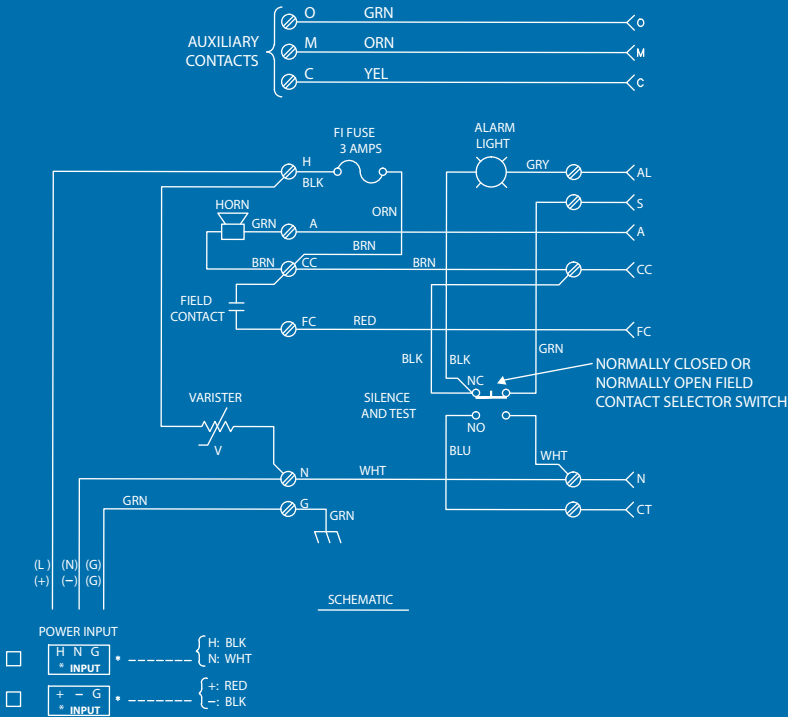

NOTES:

1. All relays shown deenergized.
2. Schematic shown with KA relay in the NC position.
3. All KA contacts reversed when the KA relay is placed in the NO position.
4. Lamp test does not operate any relays.
5. To change NO-NC field contact function, both the NO/NC selector switch and the reversible relay must be placed in the proper position.
6. Contact factory for sonalert installation.

Sequence Chart

Condition	Field Contact	Alarm Lights	Horn	KA Relay in NC Position	KA Relay in NO Position	KS Relay
Normal	Normal	Off	Off	Energized	Deenergized	Energized
Alarm	Abnormal	Flashing	On	Deenergized	Energized	Energized
Silence	Abnormal	On	Off	Deenergized	Energized	Deenergized
Normal	Normal	Off	Off	Energized	Deenergized	Energized
Lamp Test	Normal	On	Off	Energized	Deenergized	Energized

Ordering Information

X19N - () - () - ()

- 1 = Single-point Alarm
- 2 = Single-point Alarm with Sonalert
- 3 = Single-point Alarm with Beacon
- 4 = Single-point Alarm with Sonalert and Beacon
- 5 = Single-point Alarm with X36 Horn
- 6 = Single-point Alarm with X36 Horn and Beacon

Voltage:

- A = 115 VAC
- B = 24 VAC
- C = 24 VDC
- D = 48 VDC
- E = 125 VDC

Relay Type:

- GP = General Purpose
- HS = Hermetically Sealed