



Series X11CA Computer Annunciators Hardware Manual

REVISION: 1.0
DOCUMENT NUMBER: X11CA-3002
DATE: 1/6/03
EDITOR: Nana Lee, Mark Layos Ronan Engineering Company

APPROVED: V.J. _____ Date 1-14-03 _____
Project Manager

APPROVED: R.H. _____ Date 1-14-03 _____
Engineering Manager

APPROVED: A.G. _____ Date 1-14-03 _____
QA

Ronan Engineering
21200 Oxnard Street, Woodland Hills, CA 91367

TEL (818) 883-5211 FAX (818) 992-6435
Direct urgent problems to: 1-800-327-6626

© Copyright 2002 Ronan Engineering Company. All rights reserved. This document may not be reproduced or transmitted in any form, electronic or mechanical, including photocopying, recording, storing in an information retrieval system, or translating, in whole or in part, without the prior written permission of Ronan Engineering Company.

REVISION LOG

Rev #	Description	Date	By	Eng	Appr	QA
1.0		1/14/03	nLEE	VJ	RH	AG

1. OVERVIEW.....	1
1.1 Abbreviations.....	2
1.2 Revision History	3
1.3 References.....	3
1.4 Specifications and Power Requirements	3
1.4.1 System Voltage.....	3
1.4.2 Power Source (System External).....	3
1.4.3 Temperature Range.....	4
1.4.4 Inputs.....	4
1.4.5 Response Time	4
1.4.6 EMI/RFI Compatibility.....	4
1.4.7 Outputs.....	4
1.4.8 Controls.....	4
1.4.9 Diagnostic.....	4
1.4.10 Communications.....	5
1.4.11 Serial Protocols.....	5
1.4.12 Network Protocols.....	5
1.4.13 Serial.....	5
1.4.14 Special Feature.....	5
1.4.15 System Size.....	5
1.4.16 System Weight.....	5
1.4.17 Warranty.....	5
1.4.18 Approvals(Pending).....	5
2. X11CA HARDWARE.....	6
2.1 X11CA Annunciator Display Modules.....	6
2.1.1 Display and Name Plates.....	6
2.1.2 Color Coding.....	8
2.1.3 Monalarm Module: Part NO: X11CA-1000.....	9
2.1.4 Binalarm Module: Part NO: X11CA-2000.....	10
2.1.5 Trialarm Module: Part NO: X11CA-3000.....	10
2.1.6 Quadalarm Module: Part NO: X11CA-4000.....	10
2.2 X11CA Alarm Module: Part NO. X11-1047	11
2.2.1 Power Sources.....	11
2.2.2 Field Contact Inputs.....	12
2.2.3 Micro controller (U2).....	12
2.2.4 Outputs.....	12
2.2.5 RS485 Network.....	13
2.2.6 Input Response Time.....	13
2.2.7 Summary of Jumper Settings.....	13
2.3 Auxiliary Contact Module: Part NO. X11-1049	14
2.4 Cables	15
2.4.1 X11CA to X11CA-IM without PB.....	15
2.4.2 X11CA-IM (P2) to PC (RS232).....	16
2.5 Mounting.....	16
2.5.1 Mounting the Modules in the Alarm Cabinet.....	16
2.5.2 Mounting the Alarm Cabinet to the Panel.....	16
2.6 Wiring Instructions.....	19
2.6.1 X11CA-2000 Rear Terminal Arrangement and Wiring.....	19
2.6.2 X11CA-4000 Rear Terminal Arrangement and Wiring.....	20
2.7. Power Up.....	24

Table of Contents

2.8	Troubleshooting.....	25
2.8.1	General	25
2.8.2	Non-operating Alarm System.....	25
2.9	Dimension.....	25
2.9.1	Models X11CA-RelayRack Mounted Series-1000, -2000, -3000, -4000.....	26
3.	EVENT SEQUENCES	28
3.1	Options	28
3.2	Basic Sequence Types	29
3.3	First-out Sequence.....	30
3.4	Sequences of X11CA	31
3.4.1	A-1	31
3.4.2	F1A-1	32
3.4.3	F1M-1	33
3.4.4	F2A -1	34
3.4.5	F2M-1	35
3.4.6	F3A-1	36
3.4.7	F3M-1	37
3.4.8	M-1	38
4.	APPENDIX A: LIST OF FIGURES	39
5.	APPENDIX B: DATA CONVERSION (BIN TO DEC) TABLE.....	40
6.	INDEX.....	47

1. Overview

1. Overview

The RONAN Series X11CA Computer Annunciator system is a state of art annunciator group system, designed to provide the most advanced data acquisition and monitoring system that meet the requirement of the process and power industries in the most economic way.

The X11CA-Interface Module of the system provides advanced communication protocols to interface the external host computer, local network or plant network. For field contact repeater or remote group alarms it utilizes common trouble alarm and auxiliary relay outputs.

The followings are some of its key features.

- The system is offered in both the Window Annunciator model and the Remote Chassis model.
- The Window Annunciator model feature Monalarm, Binalarm, Trialarm and Quadalarm within Ronan's standard 3.5 inch (89mm) by 3.5-inch (89mm) mechanical cabinet modules.
- The Remote Logic system features high density input field contact capacity with remote light indicators.
- Each single plug-in module is internally expandable from one to four input channels and Monalarm, Bialarm, Trialarm and Quadalarm display units.
- It utilizes the state of art technology, Philips micro-controller.
- It holds up to four input alarm circuitry of high-speed conventional CMOS integrated circuit solid-state design with maximum noise immunity and reliability.
- The polarity of each field contact is set as normally open or closed using jumper switch for each channel.
- The most popular industry-wide sequences of ISA, such as A-1, A-4, A-5, A-6, F1A, F1M-1, F2A-1, F2M-1, F3A-1, and M-1 are available.
- It is powered by external 24VDC power supply.

1. Overview

- The maximum of 256 modules are allowed per system.
- Microprocessor Based system
- High noise immunity
- Field proven off-the shelf worldwide
- Serial input/output
- Comprehensive user configuration with standard windows software

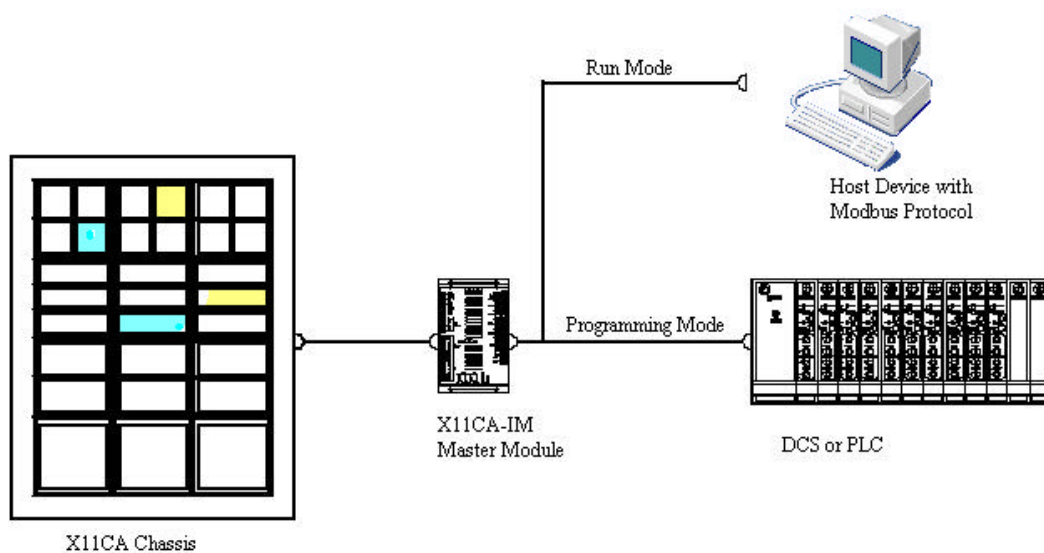

Figure 1-1 X11CA System

1.1 Abbreviations

GF	: Global Function
CTA /CA	: Common Trouble Alarm
FC	: Field Contact
MEIN	: First Out
AUX	: Auxiliary Relay
TO	: Transistor Output
H1	: Horn 1
H2	: Horn 2
NC	: Not Connected
TCP	: Transport Control Protocol.
IP	: Internet Protocol
DWG NO	: Drawing Number

1. Overview

1.2 Revision History

Revision 0.1	:	First Draft
Revision 0.2	:	Second Draft
Revision 1.0	:	First approved and released document

1.3 References

QA400	:	Design Control
QA4000	:	Design Development Quality Assurance Plan
QA4500	:	Project Archive
X11CA-3000	:	X11CA-IM Master Modules
X11CA-3001-IOM	:	X11CA Configuration Software User's Manual

1.4 Specifications and Power Requirements

1.4.1 System Voltage

- Lamps, Logic – 24 Vdc ± 20%
- Field contacts – 24 Vdc, 48 Vdc, 125 Vdc, 115 Vac, or 240 Vac

1.4.2 Power Source (System External)

- Power Supply – 115 Vac 50/60 Hz; 240 Vac 50/60 Hz
- Converter – 24 Vdc, 48 Vdc, or 125 Vdc

To specify the correct power supply, count the number of alarm modules you need to power from the supply. Calculate the total requirements as follows.

$$\text{Total Watts} = \text{Number of Modules} \times \text{Factor F} + (\text{F Aux.}) + \text{P (IM)}$$

Model	F Lamps	F LEDs	F Aux. Relay Adder	P (IM)
X11CA (1000 Series)	6.5 W	8.5 W	1 W	10 W
X11CA (2000 Series)	10.5 W	7.0 W	2 W	10 W
X11CA (3000 Series)	14.5 W	6.5 W	3 W	10 W
X11CA (4000 Series)	10.5 W	7.0 W	4 W	10 W

Match the total wattage with the next higher power rating of the Power Supply or Converter listed.

1. Overview

1.4.3 Temperature Range

- Operating – 0° to 60° C (32° to 140° F)
- Storage - -40° to +85° C (-40° to + 185° F)

1.4.4 Inputs

- Contact – Dry or Live; Normally Open / Normally Closed
- Field Selectable
- Interrogation Voltage – 24 Vdc, 48 Vdc, 125 Vdc, 115 Vac, or 240 Vac

1.4.5 Response Time

- 20 Milliseconds by default. It can be modified using the X11CA Configuration software.

1.4.6 EMI/RFI Compatibility

- CE Compliant

1.4.7 Outputs

- Visual – Fast Flash, Slow Flash, Steady ON, Intermittent Fast Flash
- Audible – Dual, Selectable by Cabinet Module
- Auxiliary Relays – Form C, Selectable Form A or B; Normally not Energized or Normally Energized
- Contact Rating – General Purpose: 1 Amps @ 28 Vdc; 0.65 Amp @ 115 Vac
- Common System Trouble – Form C, 2 Amps @ 28 Vdc; 0.65 Amp @ 115 Vac – Open Collector Transistor Output 200 mA @ 28 Vac
- Common System Reflash – Form C, 2 Amps @ 28 Vdc; 0.65 Amp @ 115 Vac – Open Collector Transistor Output 200 mA @ 28 Vac

1.4.8 Controls

- Momentary Push Button: Integral or Remote; Single Pole
- Normally Open; +V Switched; Silence; Acknowledge; Reset, Test, GP1, GP2

1.4.9 Diagnostic

- System Trouble Alarm (RUN) – Form C, 2 Amps @ 28 Vdc; 0.65 Amp @ 115 Vac
- System Trouble Alarm (RUN) – Indicating LED Green
- Communication Diagnostic (ERROR) – Indicating LED Red
- Transmit/Receiver LED Pair

1. Overview

1.4.10 Communications

- Serial – RS485 (P1) to External Host
- Network – RJ45 (TCP/IP) to External Host

1.4.11 Serial Protocols

- MODBUS RTU, Allen Bradley, DF1, DNP 3.0, Ronan Proprietary

1.4.12 Network Protocols

- TCP/IP (OPC)

1.4.13 Serial

- RS232 (P2) – System Sequence and Option Programming via Laptop or Computer
- Software – Ronan X11CA Configuration

1.4.14 Special Feature

- Alarm Storage – 256 Alarm modules with four alarm points each
- GP1, GP2 – Special Function Push-button Interface

1.4.15 System Size

- Basic Cabinet Module – 3.50 inch (88.90 mm) x 3.50 inch (88.90 mm)

1.4.16 System Weight

- Per Cabinet Module – 1.75 pounds (0.79 kg), Not Including Power Supply

1.4.17 Warranty

- Three years

1.4.18..Approvals(Pending)

- UL: Underwriters Laboratories
- CE: Cenelec
- CUL: Canadian Underwriters Laboratories

2. X11CA Hardware Setup

2. X11CA Hardware

The RONAN X11CA Computer Annunciator System with microprocessor based electronics is assembled from basic 3.50 inch (88.90 mm) by 3.50 inch (88.90 mm) modules to make up the overall size requirements and number of windows required.

The mechanical modules assembled from aluminum castings and extrusions provide excellent heat dissipation for a continuously lit annunciator system and feature the structural strength required in industrial applications.

The rear terminal is designed as a single piece molded plastic assembly per window for durability. A small 4.00 inch (101.60 mm) wide x 6.00 inch (152.40 mm) deep x 1.00 inch (25.40 mm) high module (interface module) is provided to connect the system to an external host.

2.1 X11CA Annunciator Display Modules

The X11CA Annunciator module allows field programmable selections of all commonly used ISA sequences from a host computer.

The lamp display of each module can have single, dual, triple or quad alarm channel alarm logic displays, and field contact polarity of each channel is selected by setting the jumpers on the board.

2.1.1 *Display and Name Plates*

The colored nameplates can be supplied in five standard colors, (red, green, amber, white, and blue) to distinguish such functions as fire alarm or shut down...etc.

The Sandwich nameplates, an option exclusive to RONAN Visual Annunciator, are generally supplied with white front lenses and colored back lenses. This lens combination displays all windows white in non-lit status, changing to the selected color in OFF normal condition. The Sandwich nameplates are for lamps only.

Each lamp cell uses dual bulbs with 1 watt each, except Quadalarm.

2. X11CA Hardware Setup

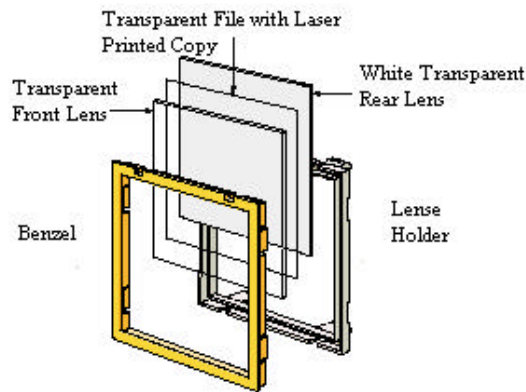

No.1. Use with LEDs
No.2. Use with LEDs

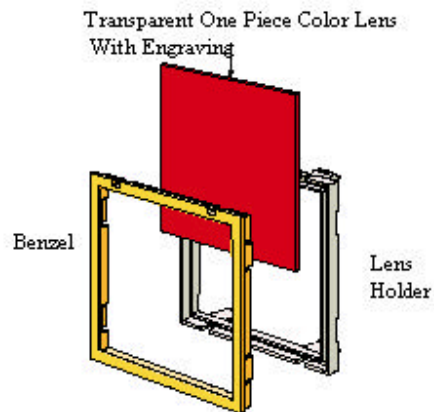

No.3. Use with Lamps

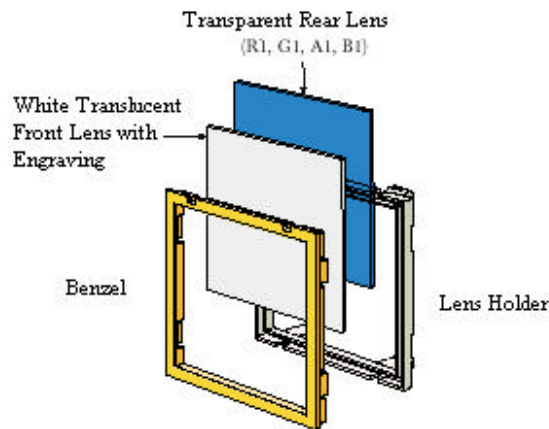

No. 4 Use with Lamps
Sandwich Type

Figure 2-1 Displays and Nameplates

2. X11CA Hardware Setup

Chassis Type	LEDS Only		Lamps Only				
	No.1		No.2		No.3	No.4	
	Front Lens	Rear Lens	Front Lens	Rear Lens	One Piece Lens	Front Lens	Rear Lens
X11CA-1000	WL1-C	WL1-W1	WL1-C	WL1-W2	WL1-(-)	WL1-W2	WL1-(-)
X11CA-2000	WL2-C	WL2-W1	WL2-C	WL2-W2	WL2-(-)	WL2-W2	WL2-(-)
X11CA-3000	WL3-C	WL3-W1	WL3-C	WL3-W2	WL3-(-)	WL3-W2	WL3-(-)
X11CA-4d000	WL4-C	WL4-W1	WL4-C	WL4-W2	WL4-(-)	WL4-W2	WL4-(-)

Engraving Colors

Black characters for (W) White Translucent lens
 White characters for (R) Red Translucent lens
 White characters for (G) Green Translucent lens
 Black characters for (A) Amber Translucent lens
 White characters for (B) Black Translucent lens

(R1) Red Transparent lens
 (G1) Green Transparent lens
 (A1) Amber Transparent lens
 (B1) Blue Transparent lens

2.1.2 Color Coding

- Eight bezel colors
 The bezels are available in eight colors (black, brown, red, yellow, green, blue, gray and white) to allow distinction of the different system functions, such as sequence types, first out groups, common alarm groups, etc.

NOTE:
 All lens holders are white colors.

2. X11CA Hardware Setup

The following is the color specification for each X11CA type.

Chassis Type	Bezel Color	Lens Holder
X11CA-1000	WB1-()	LH1
X11CA-2000	WB2-()	LH2
X11CA-3000	WB3-()	LH3
X11CA-4000	WB4-()	LH4

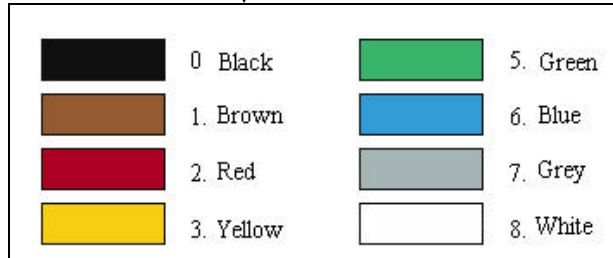

Figure 2-2 Eight Bezel Colors

- Colored lenses (not suitable for LED displays)

2.1.3 Monalarm Module: Part NO: X11CA-1000

The Monoalarm plug-in Module features single channel alarm logic with two 2-watt incandescent or optional LED type indicators illuminating a 3.00-inch (76.20 mm) high by 3.00-inch wide window.

NOTE:

Even when a lamp bulb or an LED extinguishes or burns out, the other lamp bulbs or LEDs remain functioning. The extinguished bulbs or LED can be replaced without un-plugging the module.

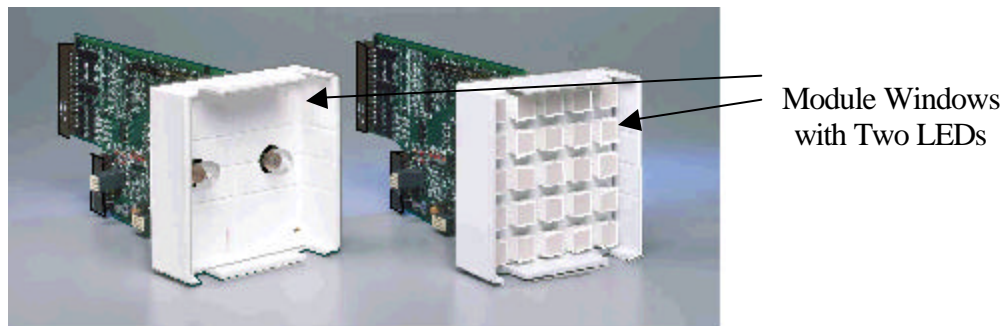

Figure 2-3 Monoalarm plug in module

Inspect the hookup wiring to insure conformity with the schematic provided on the CD. Verify that ME terminals are connected to other ME terminals only.

2. X11CA Hardware Setup

2.1.4 Bialarm Module: Part NO: X11CA-2000

The double window Bialarm Module contains two channel alarm logic with 2-watt incandescent or optional LED type indicators illuminating a 3.00-inch (76.20 mm) high by 3.00-inch wide window.

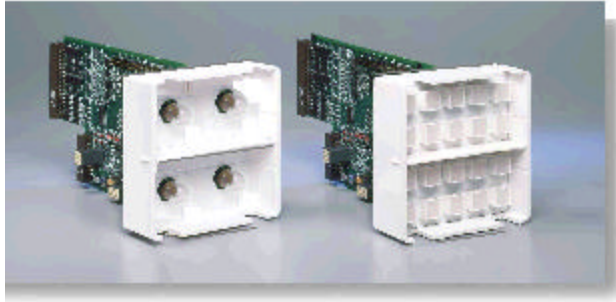

Figure 2-4 Bialarm plug in module

2.1.5 Trialarm Module: Part NO: X11CA-3000

The three window Trialarm Module provides three 0.86 inch (21.84 mm) high by 3.00 inch (76.20 mm) wide nameplates and is illuminated by three sets of two 2-watt lamps or LED type indicators. Each set is driven by one channel of the three-channel alarm logic.

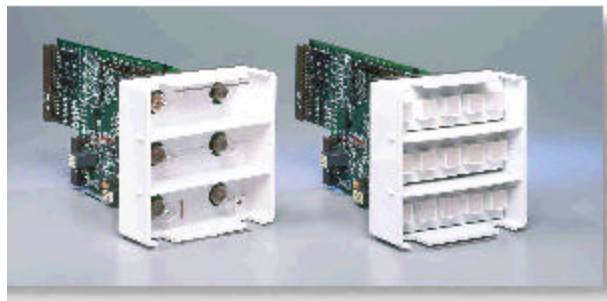

Figure 2-5 Trialarm plug in module

2.1.6 Quadalarm Module: Part NO: X11CA-4000

The four windows Quadalarm Module represent the highest density of annunciation in the X11CA series. The 1.40 inch (35.56 mm) high by 1.40 inch wide window is illuminated by two 1-watt lamps or LED indicators.

2. X11CA Hardware Setup

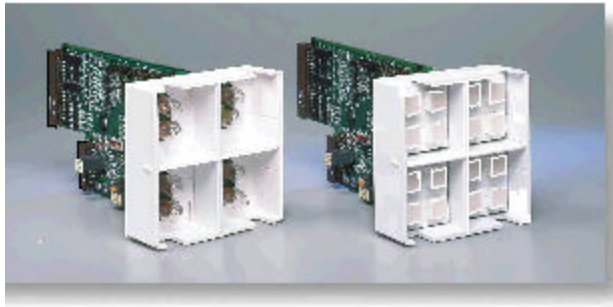

Figure 2-6 Quadalarm plug in module

2.2 X11CA Alarm Module: Part NO. X11-1047

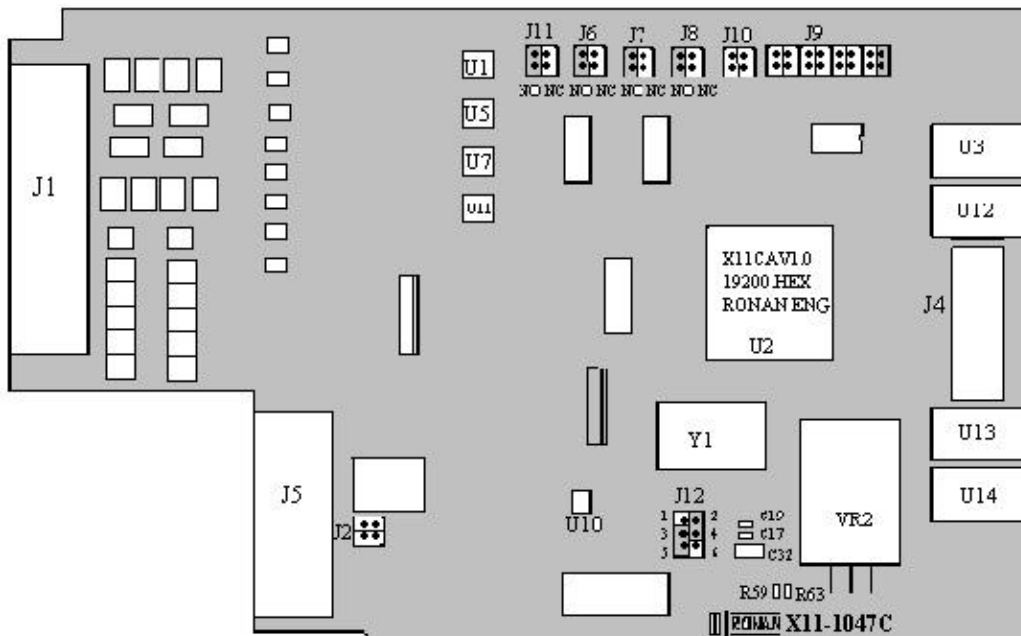

Figure 2-7 X11-1047C Module

2.2.1 Power Sources

The external 24 VDC power is supplied to the V+ jumper connector J5 (pin 7,15) and to the V- jumper connector J5 (pin 8,16) on the PC board.

The voltage regulator, VR2, and two resistors, R59 and R63, on the board reduce the voltage down to 5 VDC.

The electrolytic capacitor, C32, and two ceramic capacitors, C17 and C19, keep the voltage constant for load variations and voltage transients.

2. X11CA Hardware Setup

2.2.2 Field Contact Inputs

Field contacts can be set as normally open or normally closed by setting jumper switches (J11, J6, J7, and J8) either as NO or NC on each alarm module.

- Dry contact – The system internal interrogation powered 24 Vdc.
- Live contact – Opto-isolated inputs. The opto-couplers, U1, U5, U7 and U11, provide 2,500-volt isolation.
- 24 Vdc, 48 Vdc, 125 Vdc or 115 Vac, 240 Vac

2.2.3 Micro controller (U2)

U2 is a Single-Chip 8-Bit Micro controller manufactured in advanced CMOS process and is a derivative of the 80C51 flash micro controller family.

The device contains a non-volatile 32KB Flash program memory that is serial In Application programmable. That means the micro controller fetches a new program code and reprograms itself while the application is running in the system.

After the serial connection is made between the host computer and the X11-1047 Alarm module via the X11CA-IM (Refer to the Figure 2-17 X11CA-2000 Rear Terminal Wiring Diagram), the X11CA configuration software on the host computer uses IAP for the remote programming to erase and reprogram the content of the Flash Memory. (For reprogramming the Micro controller see X11CA Software Manual).

It is synchronized by the clock generator (Y1) that generates 18,432 MHz oscillations.

2.2.4 Outputs

- Auxiliary Output Signals:
These signals provide open collector outputs to the energized relays on the auxiliary modules, and it is programmable for various system functions.
- Transistor Output: Transistor output provides an open collector output (pulling to V), and it is programmable for various system functions. A typical application is to drive an auxiliary relay following the field contact or lamp logic.
- Lamp Drivers (U3, U12, U13, U14): Lamp drivers are designed to operate at 70V (1A) with over voltage, over temperature and short circuit protection.

2. X11CA Hardware Setup

2.2.5 RS485 Network

The X11CA Annunciator uses a typical RS-485 four-wire multidrop configuration system. All slave modules communicate with the master module, X11CA IM only, and the address of each slave module is selectable by the jumper, J9, using the binary code.

Jumper 9

Each X11CA module board must have a unique binary address to communicate with the X11CA Configuration program and the X11CA-IM. This address is determined by setting the jumper, J9.

Refer to the conversion table on page 40 to convert from 00000001_2 to $1111\ 1111_{10}$. Jumper 9 of Appendix B: Data Conversion (Bin to Dec) Table shows the switch setting for 00000001_2 .

The RS485 driver, U10, is used as a RS485 to TTL converter.

2.2.6 Input Response Time

The default response time of each point is 20 milliseconds, but it can be modified using the X11CA operating software.

2.2.7 Summary of Jumper Settings

Jumper NO.	Description	Default Settings
J1	Connector to the Terminal board (Module No. X11C451)	
J2	RS485 terminator. If both top and bottom pins are connected, RS485 termination will be enabled.	No connection except the first alarm module
J3	Not Available	
J4	Connector to the front panel of the Lamp board (Module No. X11-1038)	
J5	Connector to the Communication module (Module No. X11-1033)	
J6	Polarity of field input contact B. Either Normally Open or Normally Closed.	NO or NC.
J7	Polarity of field input contact C. Either Normally Open or Normally Closed.	NO or NC.
J8	Polarity of field input contact D. Either Normally Open or Normally Closed.	NO or NC.

2. X11CA Hardware Setup

J9	Address of the alarm module. Each alarm module must have a unique address number. For the address setting, refer to the Appendix B: Data Conversion (Bin to Dec) Table on page 40.	See the Appendix B: Data Conversion (Bin to Dec) Table
J10	Used for activating the boot trap loader during the first programming time into the firmware	Not connected
J11	Polarity of field input contact A. Either Normally Open or Normally Closed.	NO or NC
J12	Converter from R485 to TTL for Receiver and Transmission. <ul style="list-style-type: none"> ▪ Receiver: If pin 1 and 3 are connected, the converter is enabled by the micro-controller (U2). If pin 3 and 5 are connected, it is always enabled. ▪ Transmission: If pin 2 and 4 are connected, the converter is enabled by the micro-controller (U2). If pin 4 and 6 are connected, it is always enabled. 	<u>Receiver:</u> pin 3 and 5 are connected. <u>Transmission:</u> pin 2 and 4 are connected.

Figure 2-8 Summary of the X11-1047 Jumper Settings

2.3 Auxiliary Contact Module: Part NO. X11-1049

The auxiliary contact module is available with a single, dual, triple, or quad relay circuit, accommodating the window density selected. The modules can be plugged in the front of the system and may be purchased initially or added later. The terminals for the contact outputs are furnished as a part of the system. Each relay provides a selectable form A or B type contact with a rating of 2A at 28 Vdc. Normally open (Type A) or normally closed (Type B) contact is available for each alarm point at their respective rear terminal block terminals 5 and 6. The normal operation (NO/NC) can be changed on the auxiliary contact module at headers marked AUX1, AUX2, AUX3, or AUX4.

WARNING:

Before setting up the X11CA system, make sure that power to the system is completely off.

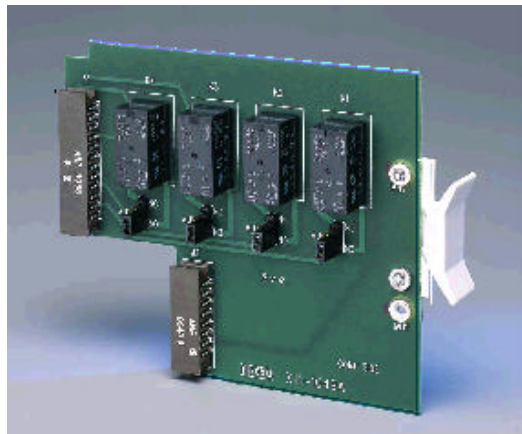

2. X11CA Hardware Setup

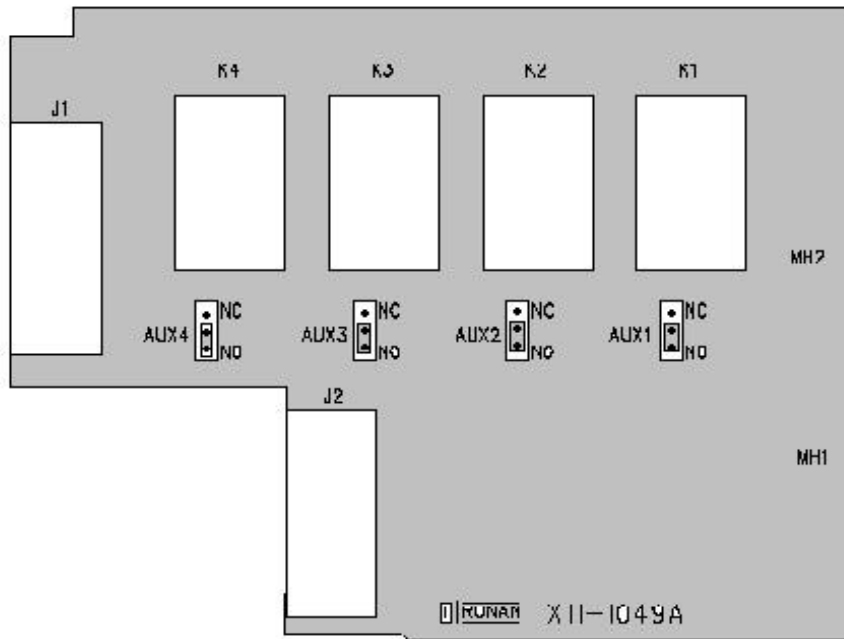

Figure 2-9 Jumper Setting on the Quad Relay Circuit

2.4 Cables

2.4.1 X11CA to X11CA-IM without PB

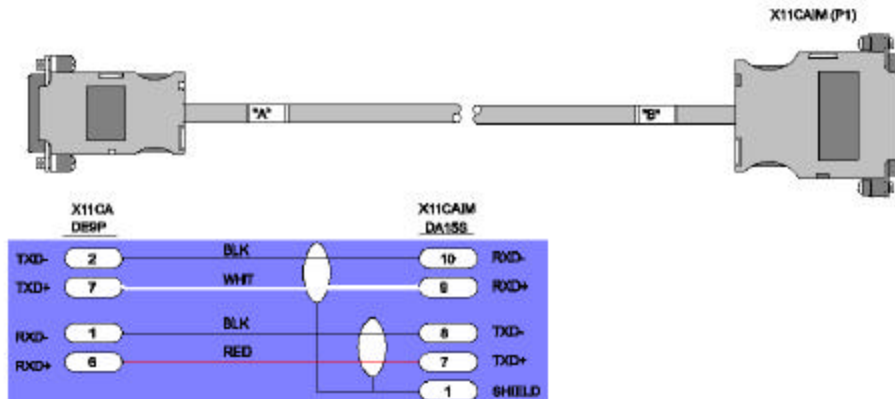

Figure 2-10 Cable for X11CA to X11CA-IM Connection

2.4.2 X11CA-IM (P2) to PC (RS232)

2. X11CA Hardware Setup

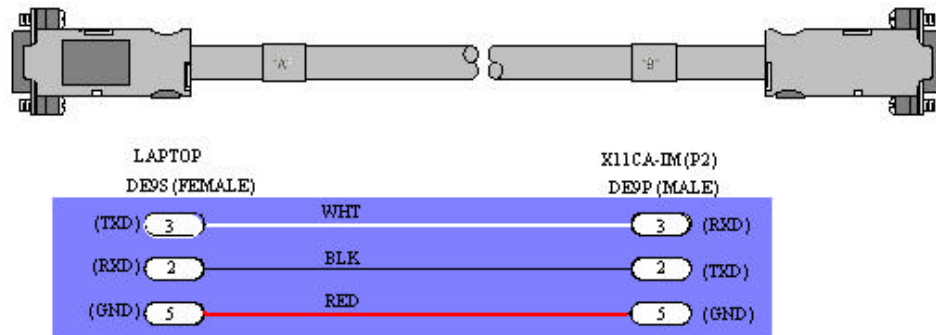

Figure 2-11 RS232 Cable from Host PC to X11CA-IM Connection

2.5 Mounting

Refer the mounting diagrams on the enclosed CD ROM, *X11CA Drawings and Sequence Chart*, for detail.

2.5.1 Mounting the Modules in the Alarm Cabinet

The annunciator is shipped with all of the alarm/lamp modules, auxiliary contact module(s) and flasher module(s) installed in the cabinet, as specified by purchase order.

External horn relay(s), reflash relay, common alarm relay, relay sockets are packed separately.

2.5.2 Mounting the Alarm Cabinet to the Panel

1. Position the X11CA alarm cabinet into the cutout hole on the panel.

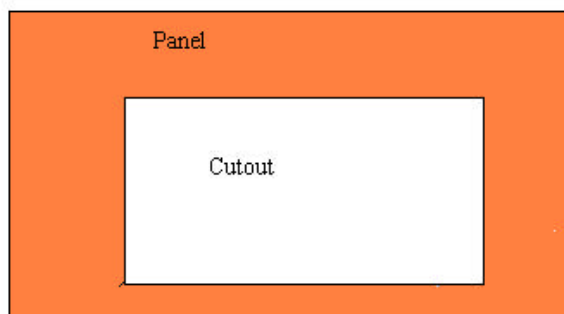

Figure 2-12 Cutout area of the panel

2. X11CA Hardware Setup

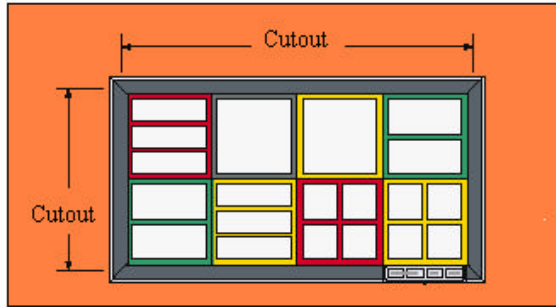

Figure 2-13 The Front View Of The Cabinet After Positioning In The Panel

2. Insert the clamp part A into the groove of the clamp part B as shown in the figure below.

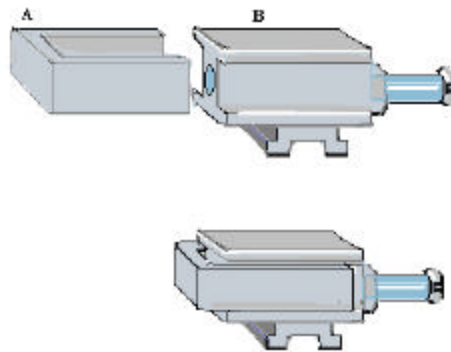

Figure 2-14 Assembling The Clamp Parts

3. Place the first clamp into the center of the groove behind the extruded trim of the cabinet and then slide it into about one third from the top left corner of the cabinet.

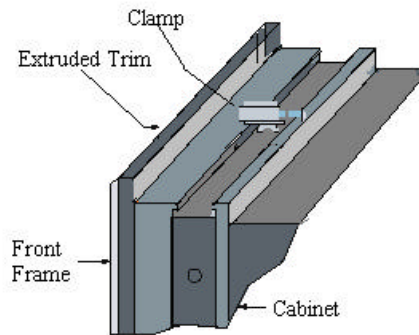

Figure 2-15 Inserting the Clamp into the Top Center of the Cabinet Groove.

2. X11CA Hardware Setup

Place the second clamp into the center of the groove behind the extruded trim of the cabinet and then slide it into about one third from the top right corner of the cabinet. Tighten each jam screw to secure the cabinet to the panel cutout. Tighten the lock nuts on each screw.

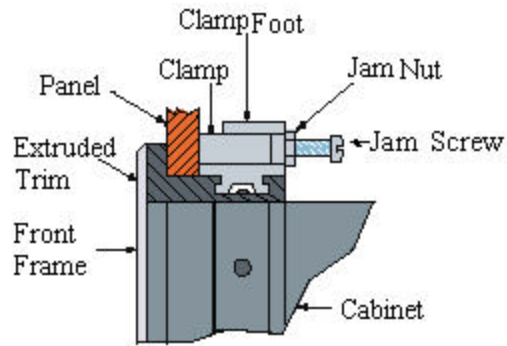
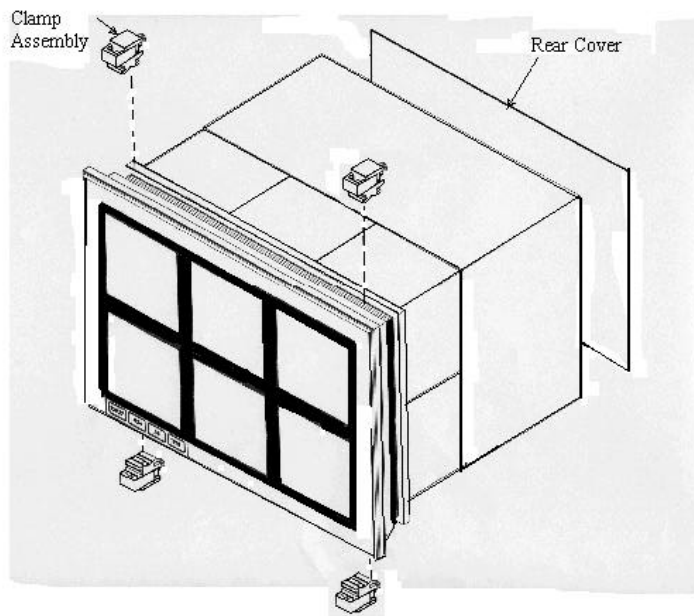

Figure 2-16 Detail A

4. Repeat step three for installing the bottom two clamps.



5. Refer to the wiring diagrams on the CD for wiring instructions.

2. X11CA Hardware Setup

2.6 Wiring Instructions

The following diagrams show rear terminal arrangement and wiring for the X11CA-2000 system and the X11CA-4000 system. For other wiring diagrams, refer to the wiring diagrams on the CD.

2.6.1 X11CA-2000 Rear Terminal Arrangement and Wiring

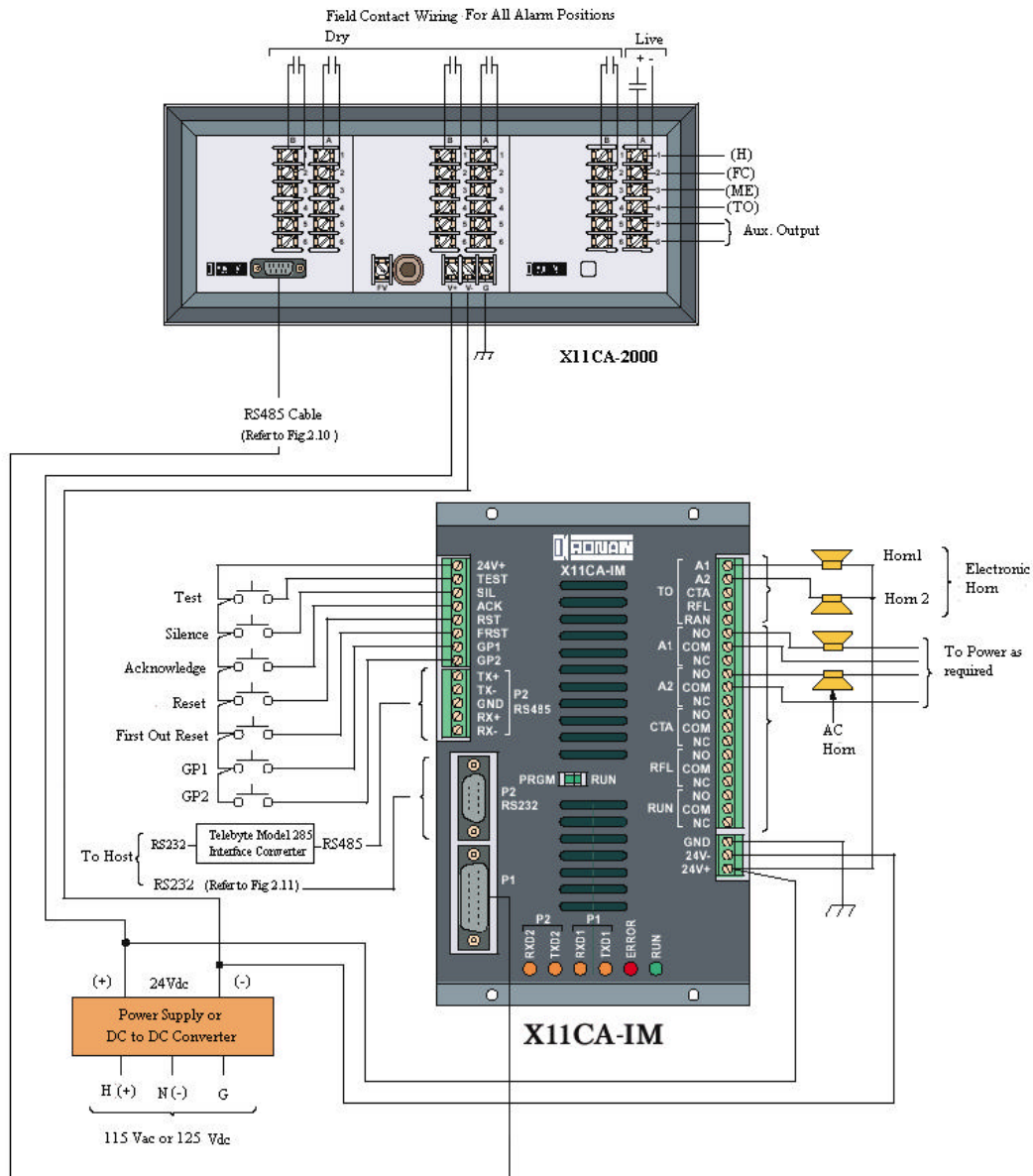

Figure 2-17 X11CA-2000 Rear Terminal Wiring Diagram

2. X11CA Hardware Setup

2.6.2 X11CA-4000 Rear Terminal Arrangement and Wiring

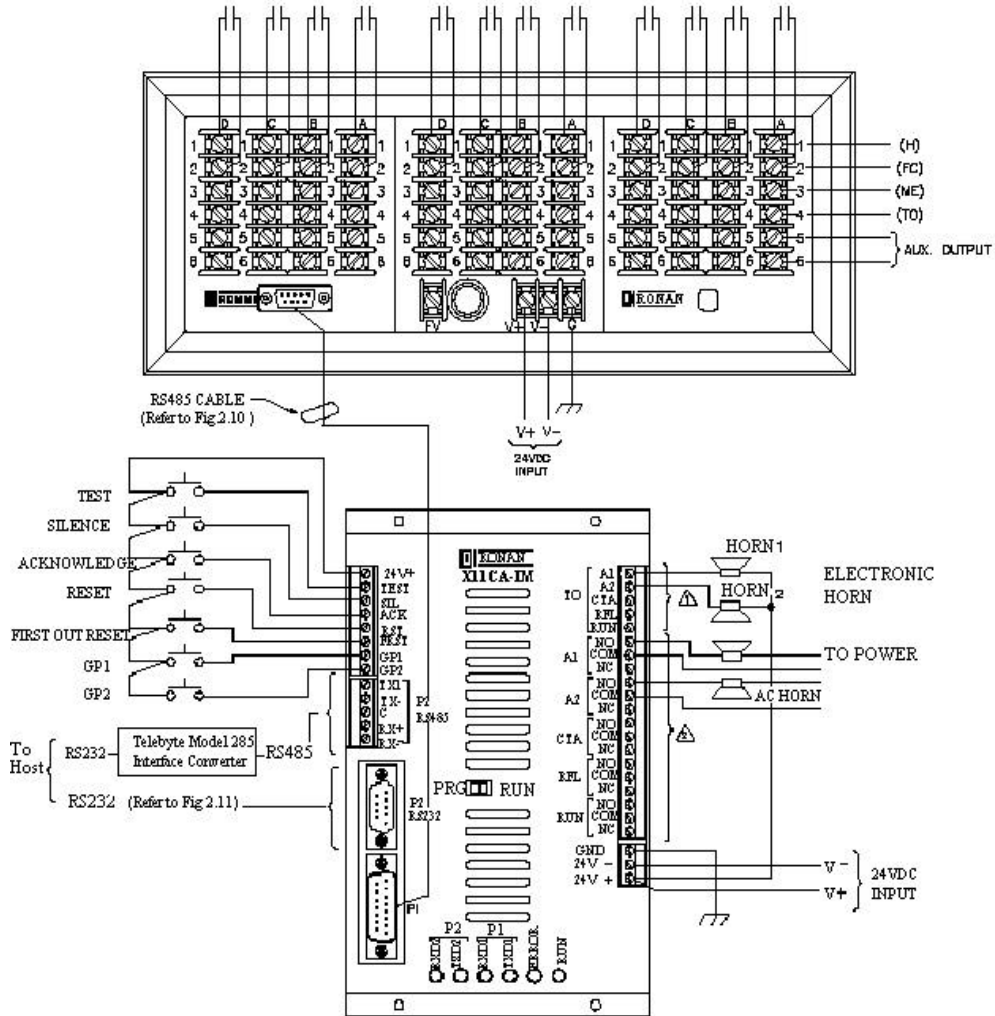

Figure 2-18 X11CA-4000 Rear Terminal Wiring Diagram

2. X11CA Hardware Setup

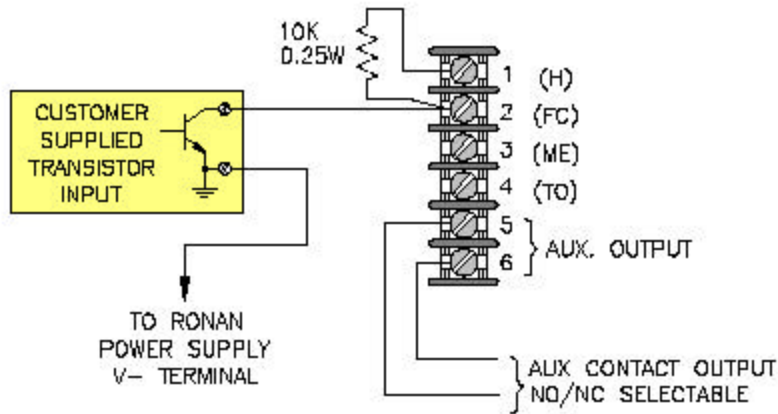

Figure 2-19 Typical transistor input (DWG NO: X11C497)

- (H) : Field contact voltage for dry contact
- (FC) : Field contact return
- (ME) : Connect all First out windows in a group.
- (TO) : Transistor output driver.
- AUX OUT : Auxiliary output - N.O./N.C. selectable

- ⚠ : T.O.: A1, A2, CTA, RFL, RUN for transistor driver
- ⚠ : A1, A2, CTA, RFL, RUN for auxiliary output
- NO : Normally opened
- COM : Common
- NC : Normally closed.
- A1 : Horn 1
- A2 : Horn 2.
- CTA : Common Trouble Alarm
- RFL : Reflash
- RUN : X11CA-IM power indication
- GP1, GP2 : Programmable inhibit function.

2. X11CA Hardware Setup

Alarm Terminal Inputs

Two basic types of terminal contacts are available.

- i. Dry contact.

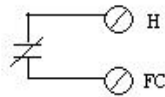

Figure 2-20. With 24Vdc system power

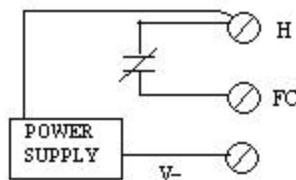

Figure 2-21. With 48Vdc, 5Vdc, 10Vdc, 125Vdc FC Source

FC source must be common to the system FC.

- ii. Opto-Coupled (Live contact)

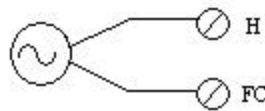

Figure 2-22. With FC source 24 Vdc/Vac, 48Vdc/Vac, 120/Vac

Each active alarm input must be wired to a customer's sensing device to set its alarm condition as either open or closed. The terminals on the alarm system for each alarm input are marked H and FC. The H terminal in the standard alarm system is the main system voltage that is supplied via a pull-up resistor on each alarm point. Each alarm input module is provided with a separate H terminal. When using a common H, it is important to jumper together the H terminals of the respective alarm cabinet modules to provide the correct amount of current source to the field contact.

2. X11CA Hardware Setup

The return wire from the field contact is wired to the FC terminal on each respective alarm module. Since the alarm system provides the power to the field contacts, it is important to verify that no other voltage source is present on either the H or FC terminals.

NOTE:

Please refer to the transmitter drawing on the enclosed CD.

In general, the solid-state alarm system is a floating system. The V+ and V- should be verified as ungrounded

Power Supply

Verify the polarity of connection to the alarm systems.

In large systems, verify that the wire sizes are efficient for high current use of the power leading to the alarm cabinets. To protect the larger alarm chassis, it is common to provide more than one input to the cabinet in which each section is provided with a separate filter, fuse and supply input terminals.

Converters

1.. DC to DC Converter

*Model - Power Failure,
Circuit Breaker, Power ON
Light, Diode Gated*

125--	24/125	--	150SCP
125--	24/125	--	300SCP
125--	24/125	--	600SCP
48--	24/125	--	150SCP
48--	24/125	--	300SCP
48--	24/125	--	600SCP

Power Output Watts
DC Voltage Out
DC Voltage In

2. X11CA Hardware Setup

2.. AC to DC Converter

115	-	24	-	125
115	-	24	-	250
115	-	24	-	375
116	-	24	-	500
115	-	24	-	750
220	-	24	-	125
220	-	24	-	250
220	-	24	-	375
220	-	24	-	500
220	-	24	-	750
115	-	24/125	-	125
115	-	24/125	-	250
115	-	24/125	-	375
115	-	24/125	-	500
115	-	24/125	-	750
115	-	24	-	250DA
115	-	24	-	375DA
115	-	24	-	500DA
115	-	24	-	750DA

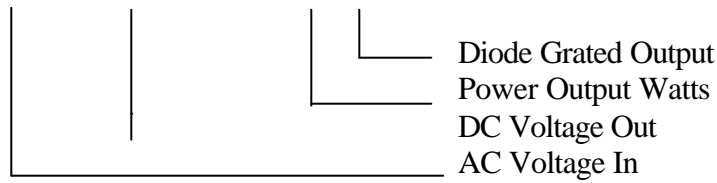

In case of multiple supply of input, make the parallel V+ and V- connections.

2.7. Power Up

Inspect the hookup wiring to insure conformity with the schematic provided. Verify that ME terminals are connected to other ME terminals only.

Turn the power on.

2. X11CA Hardware Setup

Upon the power application, the flasher module within the system will automatically initiate reset cycle. If all the associated field contacts are in normal condition, the system should then be in a quiescent state with the horn(s) off and no lamps flashing.

Press the TEST button.

(Refer to the sequence charts on the CD for the expected results.)

2.8 Troubleshooting

2.8.1 General

- No light – Check for the burned out, broken or improperly seated bulbs.
- Not functioning alarm points – Make sure that the alarm modules are properly seated in their connector.
- Power supply fuse blows each time power is applied.
 - a. Check the Power Supply Parts List or the unit instrument tag for proper fuse size.
 - b. Remove the alarm system from the supply and try again. If fuse holds, double check polarity and reconnect. If the fuse still blows, remove all alarm modules and flasher and try again. If the fuse blows at this point, the problem has been isolated to a short in the internal wiring.

2.8.2 Non-operating Alarm System

- Verify that the power source is functioning properly/
- The plus to minus voltage on the rear terminals is in the range of 18V to 28V.
- Verify each polarity.

2.9 Dimension

Refer to the files saved on the enclosed CD ROM, *X11CA Drawings and Sequence Chart*, for other dimensions.

2. X11CA Hardware Setup

2.9.1 . Models X11CA-RelayRack Mounted Series-1000, -2000, -3000. -4000

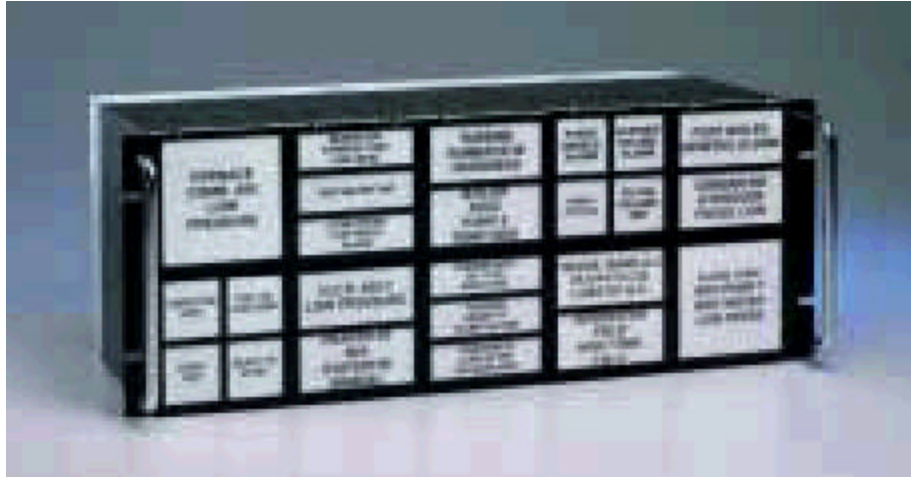
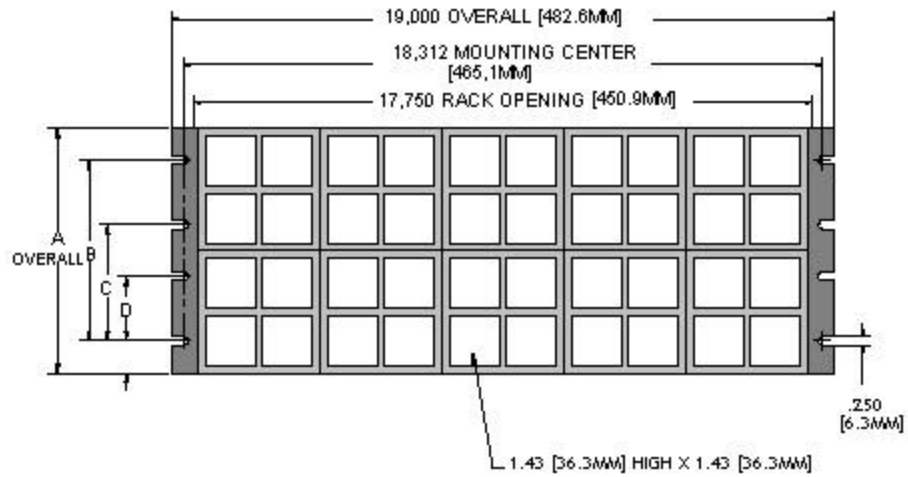

Figure 2-23 X11CA-RR



NUMBER OF WINDOWS		A OVERALL		B DIM		C DIM		D DIM		E DIM	
HIGH	WIDE	IN	MM	IN	MM	IN	MM	IN	MM	IN	MM
2	10	3.50	88.9	.25	6.4	3.00	76.2	-	-	-	-
4	10	7.00	177.8	1.50	38.1	4.00	101.6	-	-	-	-
8	10	10.50	266.7	1.50	38.1	-	-	-	-	7.50	190.5
8	10	14.00	355.6	1.50	38.1	-	-	-	-	11.00	279.4
10	10	17.50	444.5	.88	22.2	4.12	104.8	11.82	295.3	15.75	400.1
12	10	21.00	533.4	1.50	38.1	5.25	133.4	12.75	323.9	18.00	457.2

2. X11CA Hardware Setup

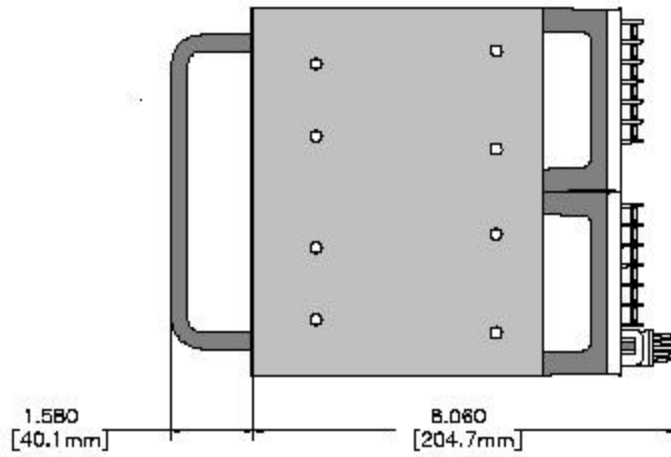

Figure 2-24 Dimensional Information of X11CA RR-4000
(DWG NO. X11C513)

3. Event Sequences

3. Event Sequences

Typical alarm sequence specification for the X11CA is as follows.

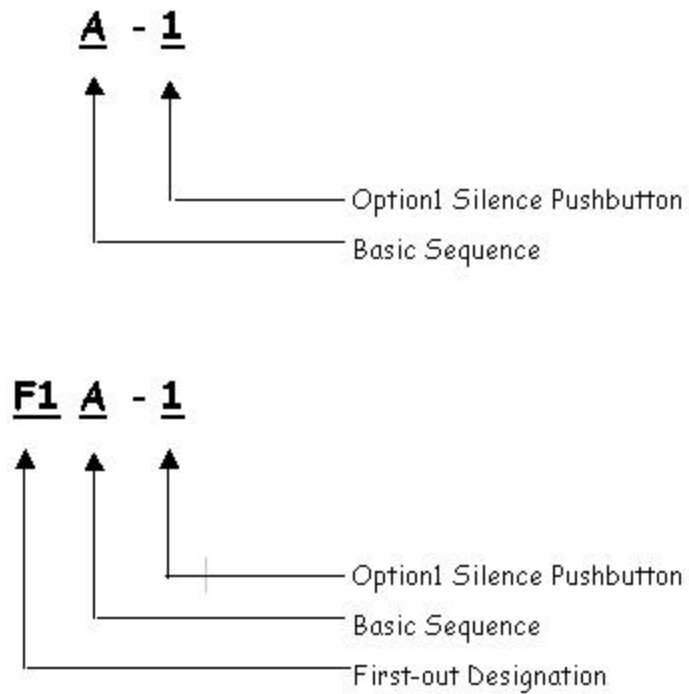
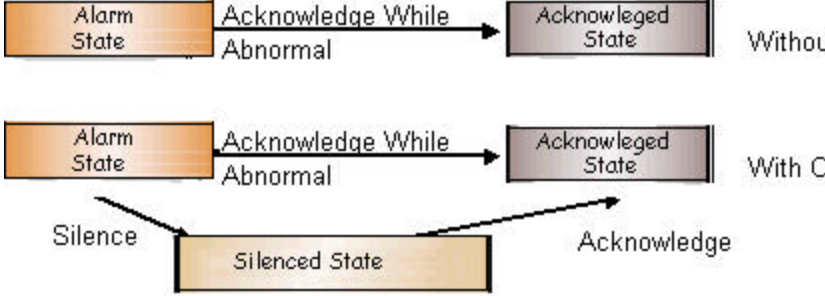
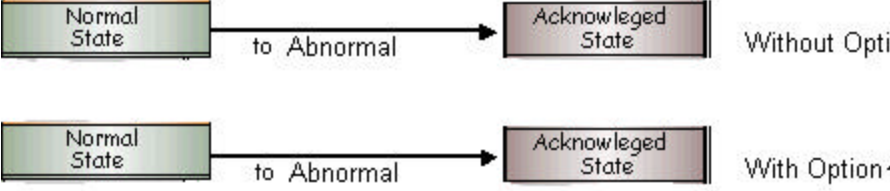

Figure 3-1 Typical Alarm Sequence Specifications.

3.1 Options

The following list has the types of options used for the X11CA.

3. Event Sequences

Options	Descriptions
1.	<p>Silence Pushbutton: A separate pushbutton is added to allow silencing the alarm audible device without affecting the visual displays.</p>  <p style="text-align: center;">Figure 3-2 Silence Pushbutton Option</p>
4	<p>No Lock-in:</p>  <p style="text-align: center;">Figure 3-3 No Lock-in Option</p>
5	No Flashing:
6	<p>No Alarm Audible No outputs on Terminals A1 and A2.</p>

3.2 Basic Sequence Types

The descriptions of the basic sequence types are listed below. Variations in the basic sequences are defined by adding the options numbers to the basic sequences.

3. Event Sequences

A	Automatic Reset: The sequence returns to the normal state automatically, after the event returns to normal and acknowledged.
M	Manual Reset: The sequence returns to the normal state, after the event returns normal, acknowledged, and reset.

3.3 First-out Sequence

First out sequences indicate which one of a group of alarm points operated first. To accomplish this, the visual display of the first alarm event must be different from the visual display of the subsequent alarm events in that group. Only one first out alarm event can exist in the group. The first out sequences are designated by a combination of the first out designation, the basic sequence letter, and the option numbers.

F1	No subsequent Alarm State: The F1 family of sequences differentiates the first alarm event of the group from the subsequent events by flashing its lamp and activating its horn. Clearing of the first alarm event allows the system to accept the next alarm in the group as the First out.
F2	No subsequent Alarm Flashing: The F2 family resets the first out alarms with the operation of the Acknowledge pushbutton. The first out alarm and subsequent alarms operate as the F1 family. Clearing of the first alarm event allows the system to accept the next alarm in the group as the First out.
F3	First Out Flashing and Reset Pushbutton: Additional types of flashing are added to identify new and acknowledged first alarms. A first out reset pushbutton is added to reset the first alarms, whether the event has returned to normal or not.

3. Event Sequences

3.4 Sequences of X11CA

3.4.1 A-1

Automatic Reset

The audible device is silenced and flashing stops when acknowledged. Acknowledgement of the alarm resets automatically when the event returns to normal.

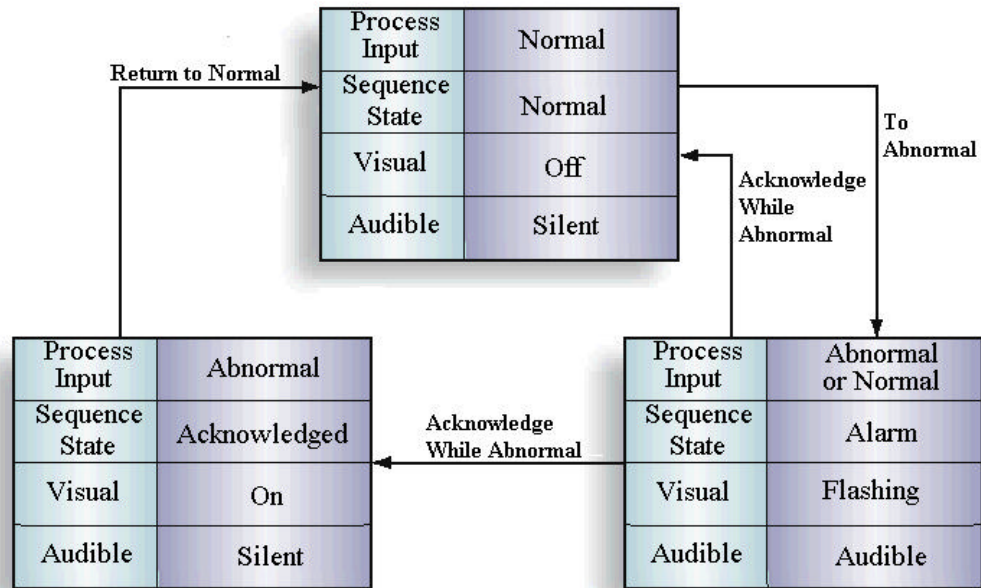

3. Event Sequences

3.4.2 F1A-1

First Out with Automatic Reset

The First Alarm operates as a basic sequence A. Subsequent alarms operate as a status lamp. The visual display of the subsequent alarms is steady on until the events return to normal, at which time the lamplights go off.

Key applications:

1. If First out is the only alarm of importance.
2. Current status of the subsequences is of interest.
3. Minimum operator action is preferred for the subsequent alarms.
4. Subsequent alarms must lock-in and be annunciated by audible and visual flashing, see sequence F3A.

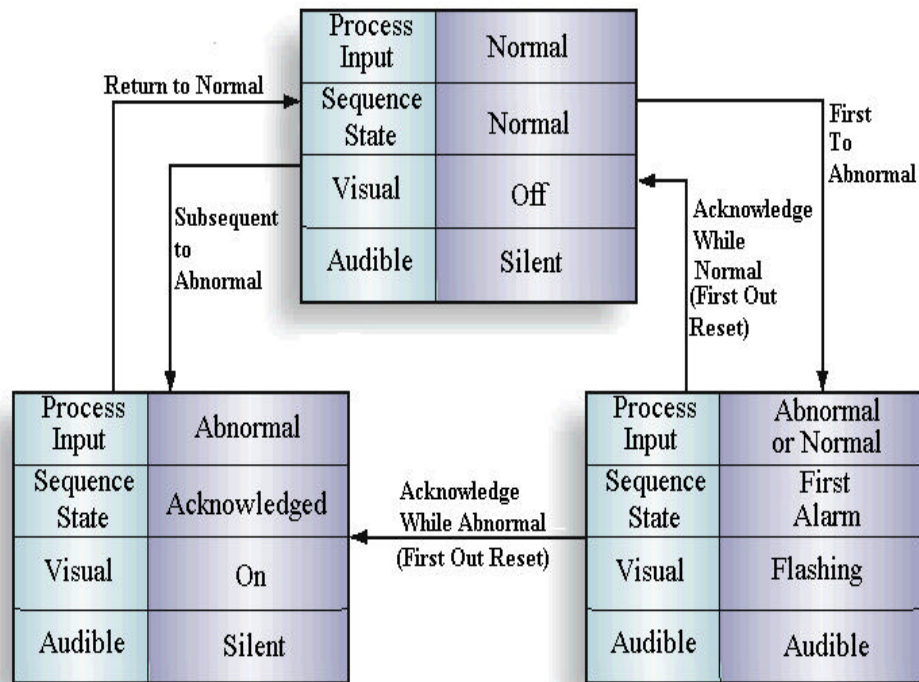

3. Event Sequences

3.4.3 FIM-1

First out with manual reset

The first alarm operates as a basic sequence M. Subsequent alarms operate as a status lamp that locks in until the events return to normal and Reset is initiated.

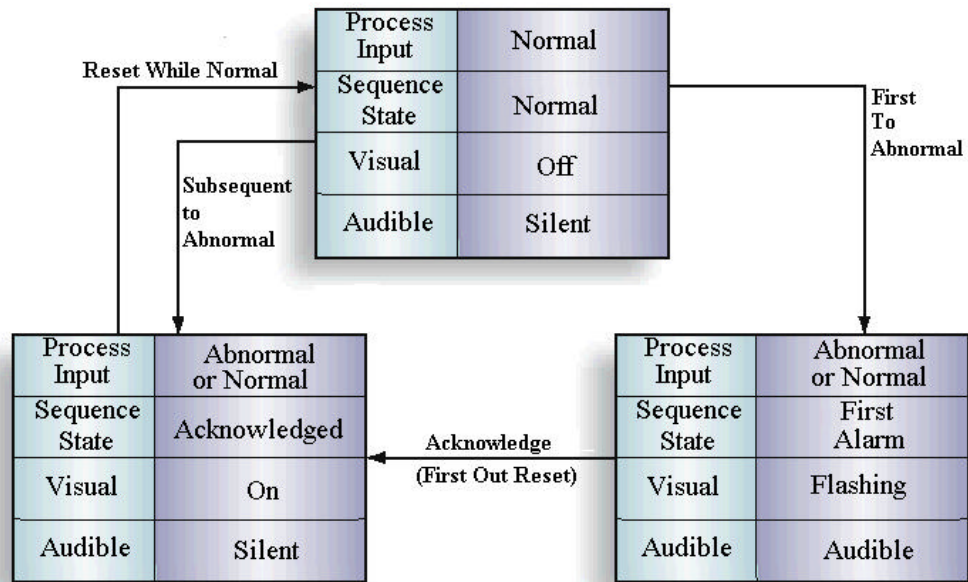

3. Event Sequences

3.4.4 F2A -1

First out automatic reset.

The first alarm operates as a basic Sequence A. subsequent alarms operate as a status lamp and also activates the audible devices. Option 1 must be used to enable the apparent operation of the audible for subsequent alarms. Subsequent alarms are locked-in and cannot return to the normal state until the Acknowledge pushbutton is activated, resetting the first out-alarm. After the inputs return to normal and acknowledgement, all input points return to the normal sequence state automatically.

Key applications:

1. First-out Alarm is of prime importance.
2. Subsequent alarms must lock-in and resound the audible if it has been silenced.
3. If Option 1 is used, the number of concurrent alarms expected is small enough that flashing is not required to locate each new subsequent alarm when the audible sounds.

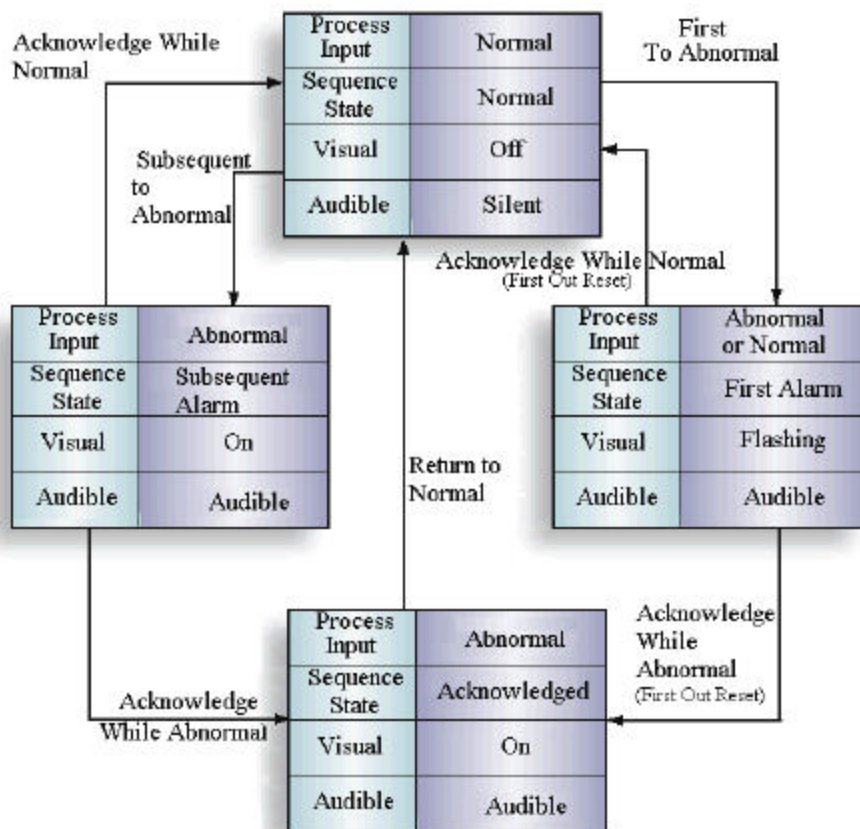

3. Event Sequences

3.4.5 F2M-1

First Out Manual Reset

The First out alarm operates as a basic sequence M. Subsequent alarms operate as a status lamp and also operate the audible. Before acknowledging the First out alarm, sequence F2M operates the same as sequence F2A. After acknowledgement, sequence F2M differs by requiring a Reset to return to normal even though the events have returned to normal.

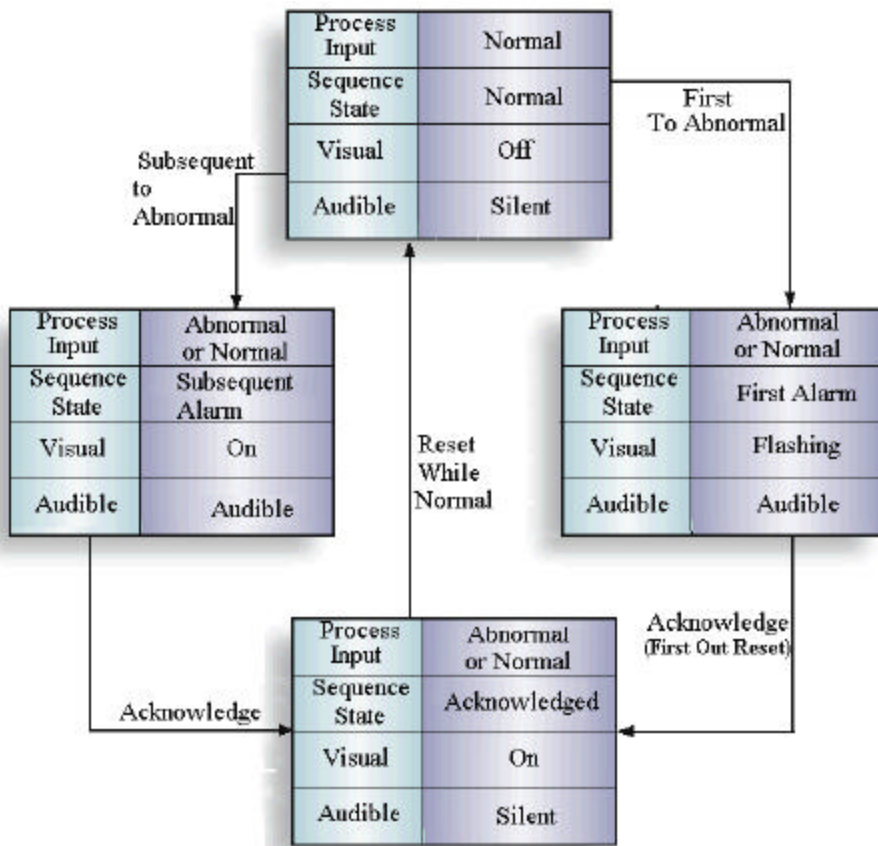

3. Event Sequences

3.4.6 F3A-1

First out.

Displaying the visual device in intermittent flashing pattern and activating the audible devices until the first function is reset distinguish the first alarm. The acknowledged first alarm is distinguished by changing the visual display as slow flashing. Subsequent alarms follow the basic sequence A. Because the Reset pushbutton is used to reset the first out function, Acknowledge can be used to sequence the subsequent alarms through a standard sequence. This makes it possible to distinguish the new subsequent alarms from the previously acknowledged subsequent alarms. Also the subsequent alarms lock in until they are acknowledged. Once acknowledged, they can automatically return to normal state when the input points return to normal.

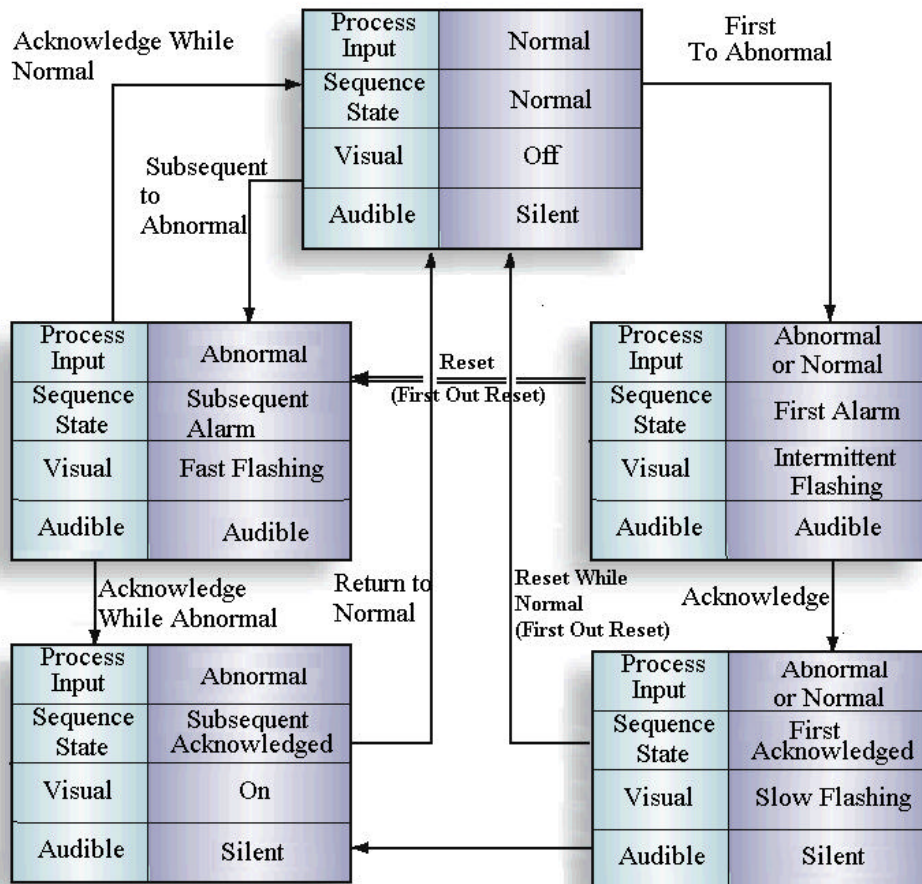

3. Event Sequences

3.4.7 F3M-1

First out manual reset.

The first out alarm in a group is distinguished by unique display until the first out function is reset. Because Acknowledge is not used to reset the first out function, the new first alarm and subsequent alarms can be acknowledged so that the new alarms can be distinguished from the previously acknowledged alarms. The subsequent alarms return to normal state only if they are in the normal state when the Reset is operated and the first out group has been reset.

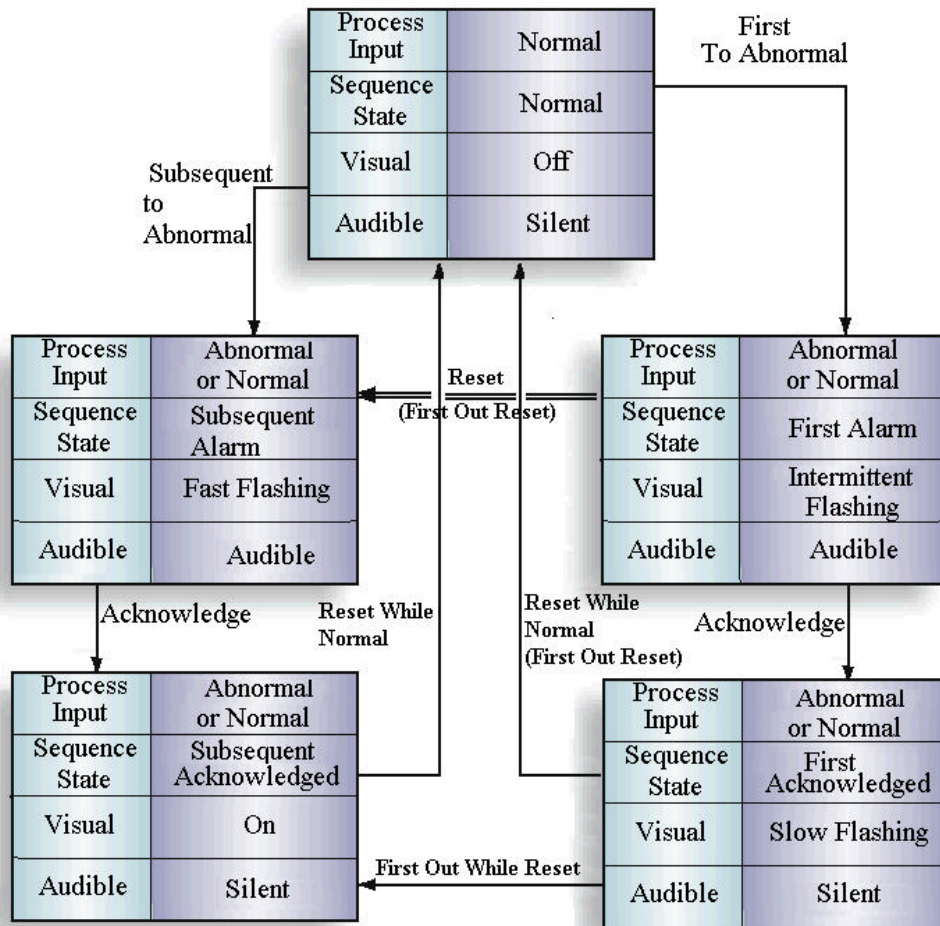

3. Event Sequences

3.4.8 M-1

Manual Reset

Sequence M is a basic alarm sequence (Horn on with Flashing Visual) with Manual Reset that retains acknowledged alarms until the process input conditions return to normal and the manual Reset pushbutton is activated. In some applications, Sequence M may have a disadvantage since new alarms that occur while the Acknowledge Pushbutton is being operated appear in the steady on condition. Any alarm occurring during the Acknowledge pushbutton operation may be confused with existing acknowledged alarms. In order to reset alarms, sequence M requires that the Reset pushbutton be operated repeatedly to determine if the process input conditions have returned to normal. Use of Options 1 and 2 improves the sequence of for reviewing new incoming alarms.

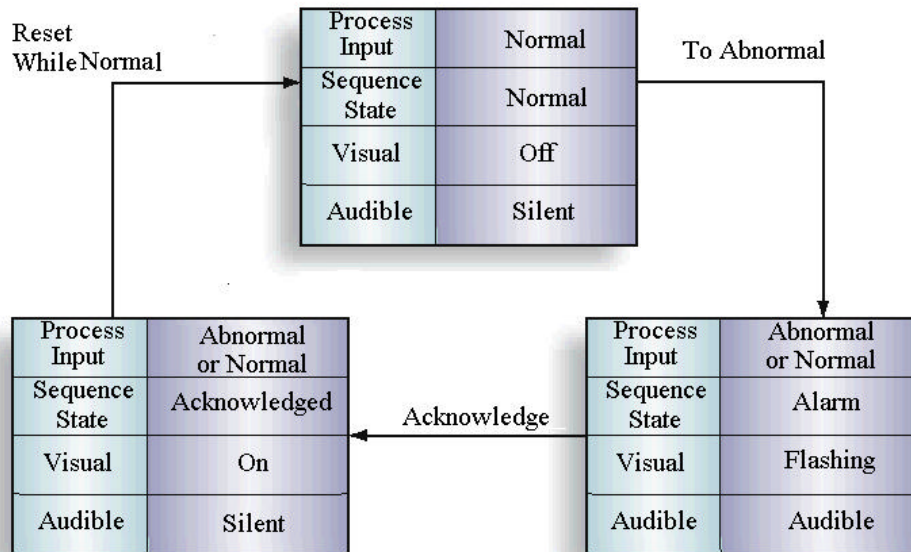

4. Appendix A: List of Figures

4. Appendix A: List of Figures

FIGURE 1-1 X11CA SYSTEM	2
FIGURE 2-1 DISPLAYS AND NAMEPLATES	7
FIGURE 2-2 EIGHT BENZEL COLORS	9
FIGURE 2-3 MONOALARM PLUG IN MODULE	9
FIGURE 2-4 BIALARM PLUG IN MODULE.....	10
FIGURE 2-5 TRIALARM PLUG IN MODULE.....	10
FIGURE 2-6 QUADALARM PLUG IN MODULE.....	11
FIGURE 2-7 X11-1047C MODULE	11
FIGURE 2-8 SUMMARY OF THE X11-1047 JUMPER SETTINGS	14
FIGURE 2-9 JUMPER SETTING ON THE QUAD RELAY CIRCUIT	15
FIGURE 2-10 CABLE FOR X11CA TO X11CA-IM CONNECTION.....	15
FIGURE 2-11 RS232 CABLE FROM HOST PC TO X11CA-IM CONNECTION	16
FIGURE 2-12 CUTOUT AREA OF THE PANEL.....	16
FIGURE 2-13 THE FRONT VIEW OF THE CABINET	17
FIGURE 2-14 ASSEMBLING THE CLAMP PARTS.....	17
FIGURE 2-15 INSERTING THE CLAMP INTO THE TOP CENTER OF THE CABINET GROOVE....	17
FIGURE 2-16 DETAIL A	18
FIGURE 2-17 X11CA-2000 REAR TERMINAL WIRING DIAGRAM	19
FIGURE 2-18 X11CA-4000 REAR TERMINAL WIRING DIAGRAM	20
FIGURE 2-19 TYPICAL TRANSISTOR INPUT (DWG NO: X11C497)	21
FIGURE 2-20. WITH 24VDC SYSTEM POWER	22
FIGURE 2-21. WITH 48VDC, 5VDC, 10VDC, 125VDC FC SOURCE.....	22
FIGURE 2-22. WITH FC SOURCE 24 VDC/VAC, 48VDC/VAC, 120/VAC.....	22
FIGURE 2-23 X11CA-RR	26
FIGURE 2-24 DIMENSIONAL INFORMATION OF X11CA RR-4000	27
FIGURE 3-1 TYPICAL ALARM SEQUENCE SPECIFICATIONS.....	28
FIGURE 3-2 SILENCE PUSHBUTTON OPTION	29
FIGURE 3-3 NO LOCK-IN OPTION.....	29

5. Appendix B: Data Conversion (Bin to Dec) Table

5. Appendix B: Data Conversion (Bin to Dec) Table

The following list shows numbers from $0000\ 0001_2$ (1_{10}) to $1111\ 1111_2$ (255_{10}).

SW8	SW7	SW6	SW5	SW4	SW3	SW2	SW1	Binary Address	Decimal Equivalent
OFF	OFF	OFF	OFF	OFF	OFF	OFF	ON	0000 0001	1
OFF	OFF	OFF	OFF	OFF	OFF	ON	OFF	0000 0010	2
OFF	OFF	OFF	OFF	OFF	OFF	ON	ON	0000 0011	3
OFF	OFF	OFF	OFF	OFF	ON	OFF	OFF	0000 0100	4
OFF	OFF	OFF	OFF	OFF	ON	OFF	ON	0000 0101	5
OFF	OFF	OFF	OFF	OFF	ON	ON	OFF	0000 0110	6
OFF	OFF	OFF	OFF	OFF	ON	ON	ON	0000 0111	7
OFF	OFF	OFF	OFF	ON	OFF	OFF	OFF	0000 1000	8
OFF	OFF	OFF	OFF	ON	OFF	OFF	ON	0000 1001	9
OFF	OFF	OFF	OFF	ON	OFF	ON	OFF	0000 1010	10
OFF	OFF	OFF	OFF	ON	OFF	ON	ON	0000 1011	11
OFF	OFF	OFF	OFF	ON	ON	OFF	OFF	0000 1100	12
OFF	OFF	OFF	OFF	ON	ON	OFF	ON	0000 1101	13
OFF	OFF	OFF	OFF	ON	ON	ON	OFF	0000 1110	14
OFF	OFF	OFF	OFF	ON	ON	ON	ON	0000 1111	15
OFF	OFF	OFF	ON	OFF	OFF	OFF	OFF	0001 0000	16
OFF	OFF	OFF	ON	OFF	OFF	OFF	ON	0001 0001	17
OFF	OFF	OFF	ON	OFF	OFF	ON	OFF	0001 0010	18
OFF	OFF	OFF	ON	OFF	OFF	ON	ON	0001 0011	19
OFF	OFF	OFF	ON	OFF	ON	OFF	OFF	0001 0100	20
OFF	OFF	OFF	ON	OFF	ON	OFF	ON	0001 0101	21
OFF	OFF	OFF	ON	OFF	ON	ON	OFF	0001 0110	22
OFF	OFF	OFF	ON	OFF	ON	ON	ON	0001 0111	23
OFF	OFF	OFF	ON	ON	OFF	OFF	OFF	0001 1000	24
OFF	OFF	OFF	ON	ON	OFF	OFF	ON	0001 1001	25
OFF	OFF	OFF	ON	ON	OFF	ON	OFF	0001 1010	26
OFF	OFF	OFF	ON	ON	OFF	ON	ON	0001 1011	27
OFF	OFF	OFF	ON	ON	ON	OFF	OFF	0001 1100	28
OFF	OFF	OFF	ON	ON	ON	OFF	ON	0001 1101	29
OFF	OFF	OFF	ON	ON	ON	ON	OFF	0001 1110	30

5. Appendix B: Data Conversion (Bin to Dec) Table

SW8	SW7	SW6	SW5	SW4	SW3	SW2	SW1	Binary Address	Decimal Equivalent
OFF	OFF	OFF	ON	ON	ON	ON	ON	0001 1111	31
OFF	OFF	ON	OFF	OFF	OFF	OFF	OFF	0010 0000	32
OFF	OFF	ON	OFF	OFF	OFF	OFF	ON	0010 0001	33
OFF	OFF	ON	OFF	OFF	OFF	ON	OFF	0010 0010	34
OFF	OFF	ON	OFF	OFF	OFF	ON	ON	0010 0011	35
OFF	OFF	ON	OFF	OFF	ON	OFF	OFF	0010 0100	36
OFF	OFF	ON	OFF	OFF	ON	OFF	ON	0010 0101	37
OFF	OFF	ON	OFF	OFF	ON	ON	OFF	0010 0110	38
OFF	OFF	ON	OFF	OFF	ON	ON	ON	0010 0111	39
OFF	OFF	ON	OFF	ON	OFF	OFF	OFF	0010 1000	40
OFF	OFF	ON	OFF	ON	OFF	OFF	ON	0010 1001	41
OFF	OFF	ON	OFF	ON	OFF	ON	OFF	0010 1010	42
OFF	OFF	ON	OFF	ON	OFF	ON	ON	0010 1011	43
OFF	OFF	ON	OFF	ON	ON	OFF	OFF	0010 1100	44
OFF	OFF	ON	OFF	ON	ON	OFF	ON	0010 1101	45
OFF	OFF	ON	OFF	ON	ON	ON	OFF	0010 1110	46
OFF	OFF	ON	OFF	ON	ON	ON	ON	0010 1111	47
OFF	OFF	ON	ON	OFF	OFF	OFF	OFF	0011 0000	48
OFF	OFF	ON	ON	OFF	OFF	OFF	ON	0011 0001	49
OFF	OFF	ON	ON	OFF	OFF	ON	OFF	0011 0010	50
OFF	OFF	ON	ON	OFF	OFF	ON	ON	0011 0011	51
OFF	OFF	ON	ON	OFF	ON	OFF	OFF	0011 0100	52
OFF	OFF	ON	ON	OFF	ON	OFF	ON	0011 0101	53
OFF	OFF	ON	ON	OFF	ON	ON	OFF	0011 0110	54
OFF	OFF	ON	ON	OFF	ON	ON	ON	0011 0111	55
OFF	OFF	ON	ON	ON	OFF	OFF	OFF	0011 1000	56
OFF	OFF	ON	ON	ON	OFF	OFF	ON	0011 1001	57
OFF	OFF	ON	ON	ON	OFF	ON	OFF	0011 1010	58
OFF	OFF	ON	ON	ON	OFF	ON	ON	0011 1011	59
OFF	OFF	ON	ON	ON	ON	OFF	OFF	0011 1100	60
OFF	OFF	ON	ON	ON	ON	OFF	ON	0011 1101	61
OFF	OFF	ON	ON	ON	ON	ON	OFF	0011 1110	62
OFF	OFF	ON	ON	ON	ON	ON	ON	0011 1111	63
OFF	ON	OFF	OFF	OFF	OFF	OFF	OFF	0100 0000	64
OFF	ON	OFF	OFF	OFF	OFF	OFF	ON	0100 0001	65
OFF	ON	OFF	OFF	OFF	OFF	ON	OFF	0100 0010	66
OFF	ON	OFF	OFF	OFF	OFF	ON	ON	0100 0011	67
OFF	ON	OFF	OFF	OFF	ON	OFF	OFF	0100 0100	68
OFF	ON	OFF	OFF	OFF	ON	OFF	ON	0100 0101	69
OFF	ON	OFF	OFF	OFF	ON	ON	OFF	0100 0110	70
OFF	ON	OFF	OFF	OFF	ON	ON	ON	0100 0111	71

5. Appendix B: Data Conversion (Bin to Dec) Table

SW8	SW7	SW6	SW5	SW4	SW3	SW2	SW1	Binary Address	Decimal Equivalent
OFF	ON	OFF	OFF	ON	OFF	OFF	OFF	0100 1000	72
OFF	ON	OFF	OFF	ON	OFF	OFF	ON	0100 1001	73
OFF	ON	OFF	OFF	ON	OFF	ON	OFF	0100 1010	74
OFF	ON	OFF	OFF	ON	OFF	ON	ON	0100 1011	75
OFF	ON	OFF	OFF	ON	ON	OFF	OFF	0100 1100	76
OFF	ON	OFF	OFF	ON	ON	OFF	ON	0100 1101	77
OFF	ON	OFF	OFF	ON	ON	ON	OFF	0100 1110	78
OFF	ON	OFF	OFF	ON	ON	ON	ON	0100 1111	79
OFF	ON	OFF	ON	OFF	OFF	OFF	OFF	0101 0000	80
OFF	ON	OFF	ON	OFF	OFF	OFF	ON	0101 0001	81
OFF	ON	OFF	ON	OFF	OFF	ON	OFF	0101 0010	82
OFF	ON	OFF	ON	OFF	OFF	ON	ON	0101 0011	83
OFF	ON	OFF	ON	OFF	ON	OFF	OFF	0101 0100	84
OFF	ON	OFF	ON	OFF	ON	OFF	ON	0101 0101	85
OFF	ON	OFF	ON	OFF	ON	ON	OFF	0101 0110	86
OFF	ON	OFF	ON	OFF	ON	ON	ON	0101 0111	87
OFF	ON	OFF	ON	ON	OFF	OFF	OFF	0101 1000	88
OFF	ON	OFF	ON	ON	OFF	OFF	ON	0101 1001	89
OFF	ON	OFF	ON	ON	OFF	ON	OFF	0101 1010	90
OFF	ON	OFF	ON	ON	OFF	ON	ON	0101 1011	91
OFF	ON	OFF	ON	ON	ON	OFF	OFF	0101 1100	92
OFF	ON	OFF	ON	ON	ON	OFF	ON	0101 1101	93
OFF	ON	OFF	ON	ON	ON	ON	OFF	0101 1110	94
OFF	ON	OFF	ON	ON	ON	ON	ON	0101 1111	95
OFF	ON	ON	OFF	OFF	OFF	OFF	OFF	0110 0000	96
OFF	ON	ON	OFF	OFF	OFF	OFF	ON	0110 0001	97
OFF	ON	ON	OFF	OFF	OFF	ON	OFF	0110 0010	98
OFF	ON	ON	OFF	OFF	OFF	ON	ON	0110 0011	99
OFF	ON	ON	OFF	OFF	ON	OFF	OFF	0110 0100	100
OFF	ON	ON	OFF	OFF	ON	OFF	ON	0110 0101	101
OFF	ON	ON	OFF	OFF	ON	ON	OFF	0110 0110	102
OFF	ON	ON	OFF	OFF	ON	ON	ON	0110 0111	103
OFF	ON	ON	OFF	ON	OFF	OFF	OFF	0110 1000	104
OFF	ON	ON	OFF	ON	OFF	OFF	ON	0110 1001	105
OFF	ON	ON	OFF	ON	OFF	ON	OFF	0110 1010	106
OFF	ON	ON	OFF	ON	OFF	ON	ON	0110 1011	107
OFF	ON	ON	OFF	ON	ON	OFF	OFF	0110 1100	108
OFF	ON	ON	OFF	ON	ON	OFF	ON	0110 1101	109
OFF	ON	ON	OFF	ON	ON	ON	OFF	0110 1110	110
OFF	ON	ON	OFF	ON	ON	ON	ON	0110 1111	111
OFF	ON	ON	ON	OFF	OFF	OFF	OFF	0111 0000	112

5. Appendix B: Data Conversion (Bin to Dec) Table

SW8	SW7	SW6	SW5	SW4	SW3	SW2	SW1	Binary Address	Decimal Equivalent
OFF	ON	ON	ON	OFF	OFF	OFF	ON	0111 0001	113
OFF	ON	ON	ON	OFF	OFF	ON	OFF	0111 0010	114
OFF	ON	ON	ON	OFF	OFF	ON	ON	0111 0011	115
OFF	ON	ON	ON	OFF	ON	OFF	OFF	0111 0100	116
OFF	ON	ON	ON	OFF	ON	OFF	ON	0111 0101	117
OFF	ON	ON	ON	OFF	ON	ON	OFF	0111 0110	118
OFF	ON	ON	ON	OFF	ON	ON	ON	0111 0111	119
OFF	ON	ON	ON	ON	OFF	OFF	OFF	0111 1000	120
OFF	ON	ON	ON	ON	OFF	OFF	ON	0111 1001	121
OFF	ON	ON	ON	ON	OFF	ON	OFF	0111 1010	122
OFF	ON	ON	ON	ON	OFF	ON	ON	0111 1011	123
OFF	ON	ON	ON	ON	ON	OFF	OFF	0111 1100	124
OFF	ON	ON	ON	ON	ON	OFF	ON	0111 1101	125
OFF	ON	ON	ON	ON	ON	ON	OFF	0111 1110	126
OFF	ON	ON	ON	ON	ON	ON	ON	0111 1111	127
ON	OFF	OFF	OFF	OFF	OFF	OFF	OFF	1000 0000	128
ON	OFF	OFF	OFF	OFF	OFF	OFF	ON	1000 0001	129
ON	OFF	OFF	OFF	OFF	OFF	ON	OFF	1000 0010	130
ON	OFF	OFF	OFF	OFF	OFF	ON	ON	1000 0011	131
ON	OFF	OFF	OFF	OFF	ON	OFF	OFF	1000 0100	132
ON	OFF	OFF	OFF	OFF	ON	OFF	ON	1000 0101	133
ON	OFF	OFF	OFF	OFF	ON	ON	OFF	1000 0110	134
ON	OFF	OFF	OFF	OFF	ON	ON	ON	1000 0111	135
ON	OFF	OFF	OFF	ON	OFF	OFF	OFF	1000 1000	136
ON	OFF	OFF	OFF	ON	OFF	OFF	ON	1000 1001	137
ON	OFF	OFF	OFF	ON	OFF	ON	OFF	1000 1010	138
ON	OFF	OFF	OFF	ON	OFF	ON	ON	1000 1011	139
ON	OFF	OFF	OFF	ON	ON	OFF	OFF	1000 1100	140
ON	OFF	OFF	OFF	ON	ON	OFF	ON	1000 1101	141
ON	OFF	OFF	OFF	ON	ON	ON	OFF	1000 1110	142
ON	OFF	OFF	OFF	ON	ON	ON	ON	1000 1111	143
ON	OFF	OFF	ON	OFF	OFF	OFF	OFF	1001 0000	144
ON	OFF	OFF	ON	OFF	OFF	OFF	ON	1001 0001	145
ON	OFF	OFF	ON	OFF	OFF	ON	OFF	1001 0010	146
ON	OFF	OFF	ON	OFF	OFF	ON	ON	1001 0011	147
ON	OFF	OFF	ON	OFF	ON	OFF	OFF	1001 0100	148
ON	OFF	OFF	ON	OFF	ON	OFF	ON	1001 0101	149
ON	OFF	OFF	ON	OFF	ON	ON	OFF	1001 0110	150
ON	OFF	OFF	ON	OFF	ON	ON	ON	1001 0111	151
ON	OFF	OFF	ON	ON	OFF	OFF	OFF	1001 1000	152
ON	OFF	OFF	ON	ON	OFF	OFF	ON	1001 1001	153

5. Appendix B: Data Conversion (Bin to Dec) Table

SW8	SW7	SW6	SW5	SW4	SW3	SW2	SW1	Binary Address	Decimal Equivalent
ON	OFF	OFF	ON	ON	OFF	ON	OFF	1001 1010	154
ON	OFF	OFF	ON	ON	OFF	ON	ON	1001 1011	155
ON	OFF	OFF	ON	ON	ON	OFF	OFF	1001 1100	156
ON	OFF	OFF	ON	ON	ON	OFF	ON	1001 1101	157
ON	OFF	OFF	ON	ON	ON	ON	OFF	1001 1110	158
ON	OFF	OFF	ON	ON	ON	ON	ON	1001 1111	159
ON	OFF	ON	OFF	OFF	OFF	OFF	OFF	1010 0000	160
ON	OFF	ON	OFF	OFF	OFF	OFF	ON	1010 0001	161
ON	OFF	ON	OFF	OFF	OFF	ON	OFF	1010 0010	162
ON	OFF	ON	OFF	OFF	OFF	ON	ON	1010 0011	163
ON	OFF	ON	OFF	OFF	ON	OFF	OFF	1010 0100	164
ON	OFF	ON	OFF	OFF	ON	OFF	ON	1010 0101	165
ON	OFF	ON	OFF	OFF	ON	ON	OFF	1010 0110	166
ON	OFF	ON	OFF	OFF	ON	ON	ON	1010 0111	167
ON	OFF	ON	OFF	ON	OFF	OFF	OFF	1010 1000	168
ON	OFF	ON	OFF	ON	OFF	OFF	ON	1010 1001	169
ON	OFF	ON	OFF	ON	OFF	ON	OFF	1010 1010	170
ON	OFF	ON	OFF	ON	OFF	ON	ON	1010 1011	171
ON	OFF	ON	OFF	ON	ON	OFF	OFF	1010 1100	172
ON	OFF	ON	OFF	ON	ON	OFF	ON	1010 1101	173
ON	OFF	ON	OFF	ON	ON	ON	OFF	1010 1110	174
ON	OFF	ON	OFF	ON	ON	ON	ON	1010 1111	175
ON	OFF	ON	ON	OFF	OFF	OFF	OFF	1011 0000	176
ON	OFF	ON	ON	OFF	OFF	OFF	ON	1011 0001	177
ON	OFF	ON	ON	OFF	OFF	ON	OFF	1011 0010	178
ON	OFF	ON	ON	OFF	OFF	ON	ON	1011 0011	179
ON	OFF	ON	ON	OFF	ON	OFF	OFF	1011 0100	180
ON	OFF	ON	ON	OFF	ON	OFF	ON	1011 0101	181
ON	OFF	ON	ON	OFF	ON	ON	OFF	1011 0110	182
ON	OFF	ON	ON	OFF	ON	ON	ON	1011 0111	183
ON	OFF	ON	ON	ON	OFF	OFF	OFF	1011 1000	184
ON	OFF	ON	ON	ON	OFF	OFF	ON	1011 1001	185
ON	OFF	ON	ON	ON	OFF	ON	OFF	1011 1010	186
ON	OFF	ON	ON	ON	OFF	ON	ON	1011 1011	187
ON	OFF	ON	ON	ON	ON	OFF	OFF	1011 1100	188
ON	OFF	ON	ON	ON	ON	OFF	ON	1011 1101	189
ON	OFF	ON	ON	ON	ON	ON	OFF	1011 1110	190
ON	OFF	ON	ON	ON	ON	ON	ON	1011 1111	191
ON	ON	OFF	OFF	OFF	OFF	OFF	OFF	1100 0000	192
ON	ON	OFF	OFF	OFF	OFF	OFF	ON	1100 0001	193
ON	ON	OFF	OFF	OFF	OFF	ON	OFF	1100 0010	194

5. Appendix B: Data Conversion (Bin to Dec) Table

SW8	SW7	SW6	SW5	SW4	SW3	SW2	SW1	Binary Address	Decimal Equivalent
ON	ON	OFF	OFF	OFF	OFF	ON	ON	1100 0011	195
ON	ON	OFF	OFF	OFF	ON	OFF	OFF	1100 0100	196
ON	ON	OFF	OFF	OFF	ON	OFF	ON	1100 0101	197
ON	ON	OFF	OFF	OFF	ON	ON	OFF	1100 0110	198
ON	ON	OFF	OFF	OFF	ON	ON	ON	1100 0111	199
ON	ON	OFF	OFF	ON	OFF	OFF	OFF	1100 1000	200
ON	ON	OFF	OFF	ON	OFF	OFF	ON	1100 1001	201
ON	ON	OFF	OFF	ON	OFF	ON	OFF	1100 1010	202
ON	ON	OFF	OFF	ON	OFF	ON	ON	1100 1011	203
ON	ON	OFF	OFF	ON	ON	OFF	OFF	1100 1100	204
ON	ON	OFF	OFF	ON	ON	OFF	ON	1100 1101	205
ON	ON	OFF	OFF	ON	ON	ON	OFF	1100 1110	206
ON	ON	OFF	OFF	ON	ON	ON	ON	1100 1111	207
ON	ON	OFF	ON	OFF	OFF	OFF	OFF	1101 0000	208
ON	ON	OFF	ON	OFF	OFF	OFF	ON	1101 0001	209
ON	ON	OFF	ON	OFF	OFF	ON	OFF	1101 0010	210
ON	ON	OFF	ON	OFF	OFF	ON	ON	1101 0011	211
ON	ON	OFF	ON	OFF	ON	OFF	OFF	1101 0100	212
ON	ON	OFF	ON	OFF	ON	OFF	ON	1101 0101	213
ON	ON	OFF	ON	OFF	ON	ON	OFF	1101 0110	214
ON	ON	OFF	ON	OFF	ON	ON	ON	1101 0111	215
ON	ON	OFF	ON	ON	OFF	OFF	OFF	1101 1000	216
ON	ON	OFF	ON	ON	OFF	OFF	ON	1101 1001	217
ON	ON	OFF	ON	ON	OFF	ON	OFF	1101 1010	218
ON	ON	OFF	ON	ON	OFF	ON	ON	1101 1011	219
ON	ON	OFF	ON	ON	ON	OFF	OFF	1101 1100	220
ON	ON	OFF	ON	ON	ON	OFF	ON	1101 1101	221
ON	ON	OFF	ON	ON	ON	ON	OFF	1101 1110	222
ON	ON	OFF	ON	ON	ON	ON	ON	1101 1111	223
ON	ON	ON	OFF	OFF	OFF	OFF	OFF	1110 0000	224
ON	ON	ON	OFF	OFF	OFF	OFF	ON	1110 0001	225
ON	ON	ON	OFF	OFF	OFF	ON	OFF	1110 0010	226
ON	ON	ON	OFF	OFF	OFF	ON	ON	1110 0011	227
ON	ON	ON	OFF	OFF	ON	OFF	OFF	1110 0100	228
ON	ON	ON	OFF	OFF	ON	OFF	ON	1110 0101	229
ON	ON	ON	OFF	OFF	ON	ON	OFF	1110 0110	230
ON	ON	ON	OFF	OFF	ON	ON	ON	1110 0111	231
ON	ON	ON	OFF	ON	OFF	OFF	OFF	1110 1000	232
ON	ON	ON	OFF	ON	OFF	OFF	ON	1110 1001	233
ON	ON	ON	OFF	ON	OFF	ON	OFF	1110 1010	234
ON	ON	ON	OFF	ON	OFF	ON	ON	1110 1011	235

5. Appendix B: Data Conversion (Bin to Dec) Table

SW8	SW7	SW6	SW5	SW4	SW3	SW2	SW1	Binary Address	Decimal Equivalent
ON	ON	ON	OFF	ON	ON	OFF	OFF	11110 1100	236
ON	ON	ON	OFF	ON	ON	OFF	ON	11110 1101	237
ON	ON	ON	OFF	ON	ON	ON	OFF	11110 1110	238
ON	ON	ON	OFF	ON	ON	ON	ON	11110 1111	239
ON	ON	ON	ON	OFF	OFF	OFF	OFF	11111 0000	240
ON	ON	ON	ON	OFF	OFF	OFF	ON	11111 0001	241
ON	ON	ON	ON	OFF	OFF	ON	OFF	11111 0010	242
ON	ON	ON	ON	OFF	OFF	ON	ON	11111 0011	243
ON	ON	ON	ON	OFF	ON	OFF	OFF	11111 0100	244
ON	ON	ON	ON	OFF	ON	OFF	ON	11111 0101	245
ON	ON	ON	ON	OFF	ON	ON	OFF	11111 0110	246
ON	ON	ON	ON	OFF	ON	ON	ON	11111 0111	247
ON	ON	ON	ON	ON	OFF	OFF	OFF	11111 1000	248
ON	ON	ON	ON	ON	OFF	OFF	ON	11111 1001	249
ON	ON	ON	ON	ON	OFF	ON	OFF1	11111 1010	250
ON	ON	ON	ON	ON	OFF	ON	ON	11111 1011	251
ON	ON	ON	ON	ON	ON	OFF	OFF	11111 1100	252
ON	ON	ON	ON	ON	ON	OFF	ON	11111 1101	253
ON	ON	ON	ON	ON	ON	ON	OFF	11111 1110	254
ON	ON	ON	ON	ON	ON	ON	ON	11111 1111	255

6. INDEX

6. INDEX

A

Abbreviations · 2
Auxiliary Contact · 14

C

Cable
X11CA-IM (P2) to PC (RS232) · 15
Cables
X11CA to X11CA-IM without PB ·
15

D

Dimension · 25

M

Mounting · 16

P

Part NO. X11-1047 · 11
Part NO. X11-1049 · 14

S

Sequence
A-1 · 31
F1A-1 · 32
F1M-1 · 33
F2A-1 · 34
F2M-1 · 35
F3A-1 · 36
F3M-1 · 37
M-1 · 38

Specifications · 28

Specifications

Communications · 5

System Specifications

Approvals · 5

Communications · 5

Controls · 4

Diagnostic · 4

EMI/RFI Compatibility · 4

Inputs · 4

Outputs · 4

Power source · 3

Response time · 4

Serial · 5

Special Feature · 5

System Size · 5

system voltage · 3

System Weight · 5

Temperature Range · 4

Warranty · 5

System Specifications · 3

W

Wiring

Transistor input · 21

X11CA-2000 Rear Terminal · 19, 20

X

X11CA Alarm Module · 11

Jumper settings · 13

X11CA Annunciator

Binalarm Module · 9

Color Coding · 8

Display and Name Plates · 6

Monalarm Module · 9

Quadalarm Module · 10

6. INDEX

Trialarm Module · 10

X11CA Annunciator · 6

6. INDEX
