



SOLID STATE ALARM SYSTEMS SERIES X11



BUY RONAN, THE BEST.

The Ronan Series X11 Window Annunciator Systems are designed to serve the standard process monitor market, providing economy while maintaining quality, performance, and appearance. The system features Monalarm, Binalarm and Trialarm displays within Ronan's standard 3.5 inch (89 mm) by 3.5 inch (89 mm) mechanical cabinet modules. The single plug-in module construction contains single or multi-point alarm circuitry of conventional solid state design with maximum noise immunity and reliability. The most popular industry-wide sequences and normally open/normally closed field contact logic are resident on the circuit

board, DIP switch selectable. A system common trouble alarm and a point alarm output may be utilized for remote group alarms, or fed to integrally mounted auxiliary relays, upgrading the transistor type output switches to dry contact outputs. A separate integral auxiliary contact module supplied initially, or added later in the field, contains one to three relays, depending on the system's window density. A set of contact output terminals on a mounting plate is added to the points where repeater contacts are desired. A system's common reflash output allows remote re-annunciation of any one window going into alarm.

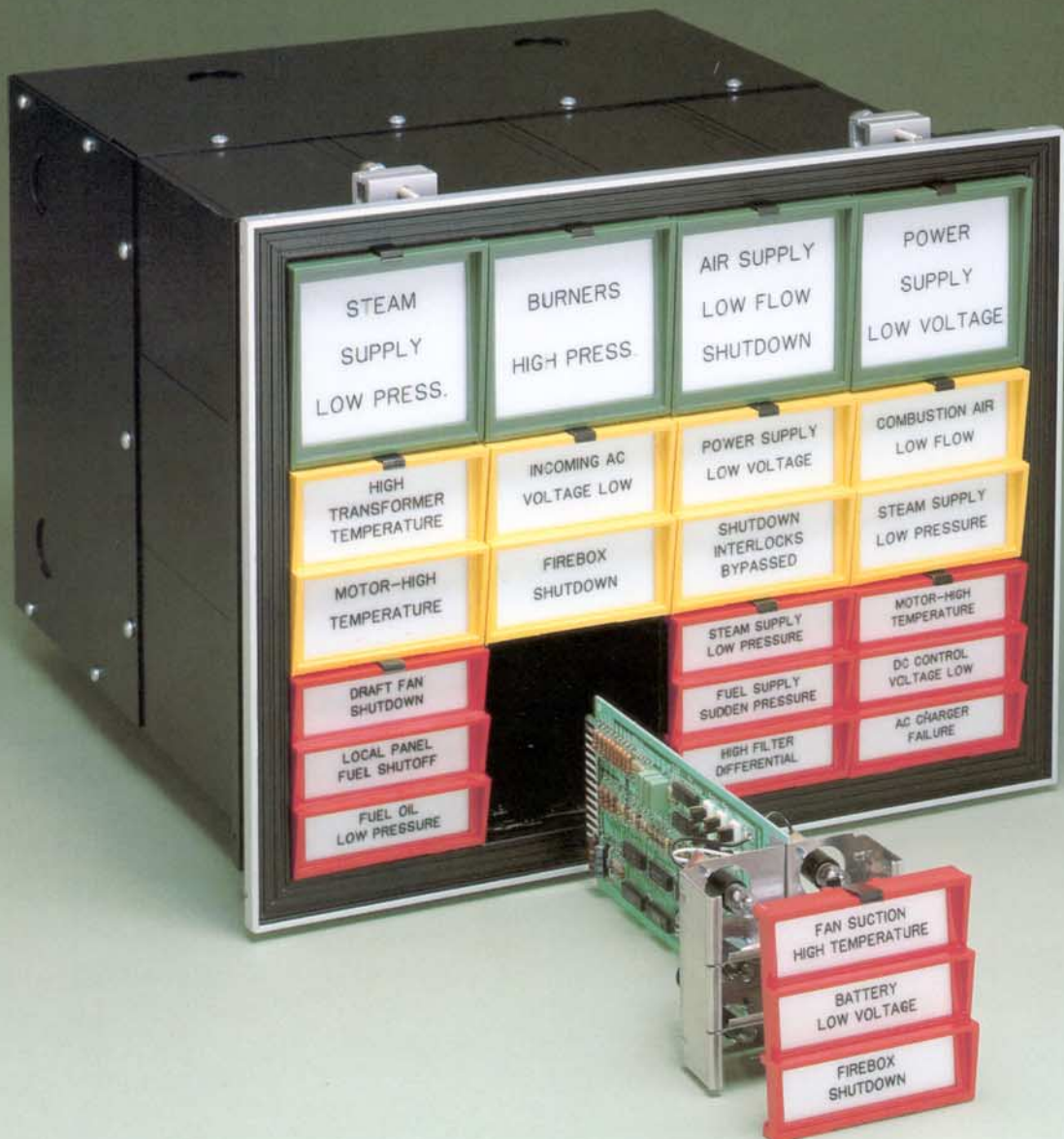

SYSTEM FUNCTIONS

INPUTS

Digital

- Dry Contact – Normally Open/Normally Closed
- 24VDC Field Contact Voltage
- Optional 125VDC Field Contact Voltage
- Optional 115VAC Live Field Contact Voltage

SEQUENCE

Dual Sequence – Switch Selectable

ISA-A and ISA-F3A

ISA-A and ISA-M

Optional ISA-A1 Ring Back ISA-R

Multi First-Out Grouping Within System

OUTPUTS

Single Audible

Auxiliary Contact

- Single-Pole, Double-Throw (Form C)
- May Be Added in the Field
- Relay Normally Non-Energized
- GP or HS Relays Available

Common System Trouble Alarm

Individual Trouble Alarm If Not Used
for Auxiliary Relay

Reflash – Pulse Output for Each New Alarm

FEATURES

Design Technology – CMOS

- High Noise Immunity
- Field Proven
- Available Off-the-Shelf, Worldwide
- No Custom Integrated Circuits

Expandability

- By Simple Exchange of Modules
- Up to 3 Times Original Number of Points
- No Internal Wiring Change

Quality Construction

- All Aluminum Extrusions and Castings
- Excellent Heatsinking
- Modular Assembly
- Maximum Flexibility in System Sizing
- Easy Panel Mounting
- Rugged Construction

Color Coding

- Eight Bezel Colors
- Colored Lenses
- Sandwich Lenses

SERVICES

Custom Designed Systems

Custom Designed Logic

Customer Training

Complete System Documentation

Field Service and Start-Up

WARRANTY

Three (3) Years

FIELD SERVICE

Worldwide Sales and Service Offices

Complete Manufacturing Facilities in USA, Canada,
and U.K.

APPROVALS AVAILABLE

UL – Underwriters Laboratories

CSA – Canadian Standard Association

CONTENTS

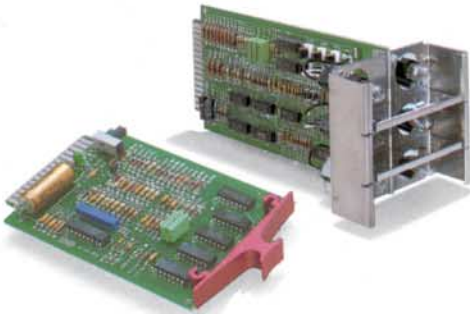

Buy Ronan, The Best	2
System Functions	3
Systems Enclosures	5
Monalarm Series	6
Binalarm Series	7
Trialarm Series	8
Sequences	9
Alarm Modules	10
Flasher/Pushbutton/Flasher Modules	11
Nameplate Engravings	12
Power Supplies/Inverters	13
Accessories — Pushbuttons/Horns	14
Typical Ordering Information	15

3-Year Warranty

Ronan warrants equipment of its own manufacture to be free from defects in material and workmanship, under normal conditions of use and service, and will repair or replace any component found to be defective, on its return, transportation charges prepaid, within three years of its original purchase. This warranty carries no liability, either expressed or implied, beyond our obligations to replace the unit which carries the warranty.

SYSTEMS ENCLOSURES

The Ronan enclosures for annunciators with integral electronics are assembled from basic 3.5 inch (89 mm) by 3.5 inch (89 mm) mechanical modules to overall size and requirements specified. This allows the greatest flexibility to adapt to the customer's control panel dimensions. The aluminum

extrusion modules provide excellent heat dissipation for a continuously lit annunciator system and feature structural strength required in industrial applications. The enclosures are painted with black, baked, semi-gloss enamel; custom colors may be supplied optionally.

The panel mount enclosure may be enhanced with a NEMA 4 or NEMA 12 door assembly to seal the front of the alarm system against the control panel where it is subject to moisture or a corrosive atmosphere. The door is supplied with a clear acrylic window, sealed with a neoprene gasket. Gasketing is supplied for sealing between door frame and control panel.

Note: The panel cutout is the same as specified in the standard flush mounted alarm system.



The flush-mounting NEMA 1 type enclosure, for control panel applications, feeds through a rectangular cutout and attaches to the panel with a number of simple clamping devices supplied with each system. The rear accessible terminals are enclosed with protective side and rear panels. The side panels feature pre-stamped conduit knockout entries for field wiring and power input.

The Ronan alarm systems of various window sizes are available for standard 19 inch (483 mm) or 24 inch (610 mm) relay rack mounting. The five mechanical module wide unit is suitable for 19 inch (483 mm), and the six module wide unit for 24 inch (610 mm) rack spacing.



System Expandability

The Series X11 Annunciator Systems may be initially ordered with an expandability option, where the Monalarm System allows field expansion to either Binalarm or Trialarm and the Binalarm to Trialarm by simple exchange of alarm/lamp modules and the appropriate bezel.

The nominal cost addition for the expansion capability makes this feature highly justifiable, if the number of required windows may increase during the life of the alarm system. When converting to the expanded system, an allowance will be made on undamaged Modules and Bezels returned within the warranty period.

MONALARM SERIES

Model X11-1000 Flushmounting Type for Control Panels Nameplate Size 2.75" (70 mm) × 3.00" (76 mm)

These systems are expandable and intermixable.

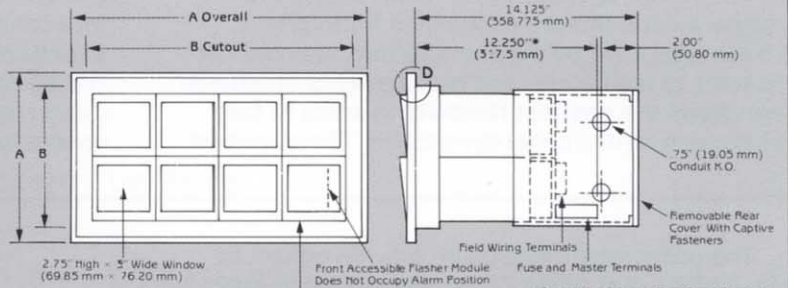
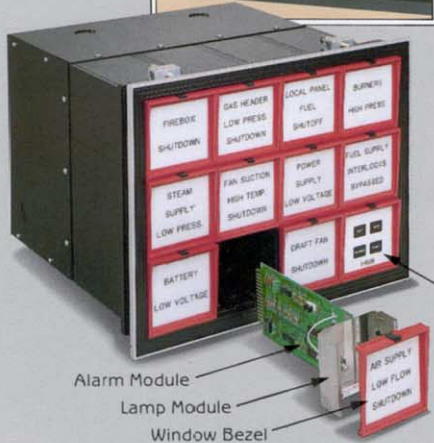

Option: Pushbutton Module Standard Position; Other Positions Optional

* Depth With Side and Rear Cover Removed
Note: Standard Finish Baked Enamel Black

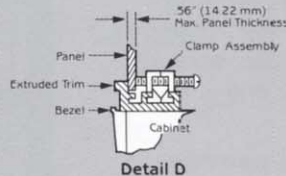

*Pushbutton Stations

The integral Pushbutton Station shown is available as an option and may occupy any position in the system. Pushbutton stations will operate in conjunction with externally wired pushbuttons. The lower, right hand position also houses the Flasher/Horn Driver Module.

Number of Windows High or Wide	A Overall		B Cutout	
	In.	mm	In.	mm
1	5.00	127.0	4.38	111.1
2	8.50	215.9	7.88	200.0
3	12.00	304.8	11.38	288.9
4	15.50	393.7	14.88	377.8
5	19.00	482.6	18.38	466.7
6	22.50	571.5	21.88	555.6
7	26.00	660.4	25.38	644.5
8	29.50	749.3	28.88	733.4
9	33.00	838.2	32.50	825.5
10	36.50	927.1	36.00	914.4
11	40.00	1016.0	39.50	1003.3
12	43.50	1104.9	43.00	1092.2

Model X11RR-1000 Relay Rack Mounting Type 19 Inch Rack Mounting – Standard 24 Inch Rack Mounting – Optional

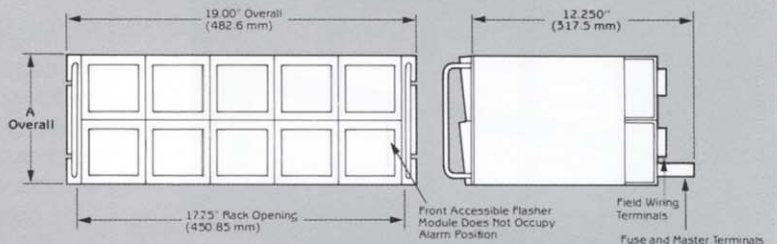

*Not limited to 4 high
**Limited to 5 wide only (19 inch, 483mm rack)
Also available 6 wide (24 inch, 610 mm rack)

Number of Windows	A Overall	
	High	Wide
1	5**	3.5
2	5	7.0
3	5	10.5
4*	5	14.0

Series X11-1000 Rear Terminal Arrangement and Wiring Information

Field Contact Input

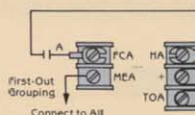

Aux. Relay Contact Outputs

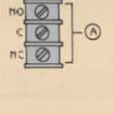

Master Terminals

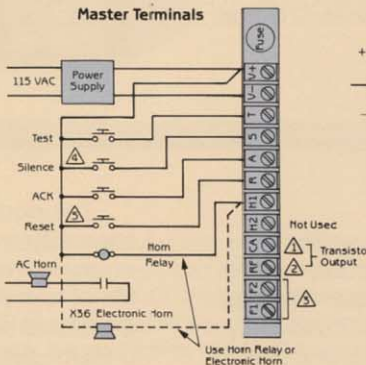

Alarm Module Output

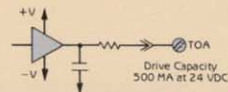

Aux. Contact Module Output

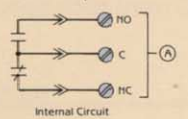

Notes:

- ⚠ CA Terminal Provides Logic Zero as Long as Any Point in the System Is in Alarm
- ⚠ RF Terminal Provides an Output Pulse to Refresh a Remote Annunciator as New Points Alarm
- ⚠ F1,F2 Flasher Sync Connection for Multichassis Applications
- ⚠ Silence Pushbutton Optional, Not Required for Operation
- ⚠ Reset Pushbutton Only Used for F3A Sequence

BINALARM SERIES

Model X11-2000 Flush Mounting Type for Control Panels Nameplate Size 1.44" (36 mm) × 3.00" (76 mm)

These systems are expandable and intermixable.

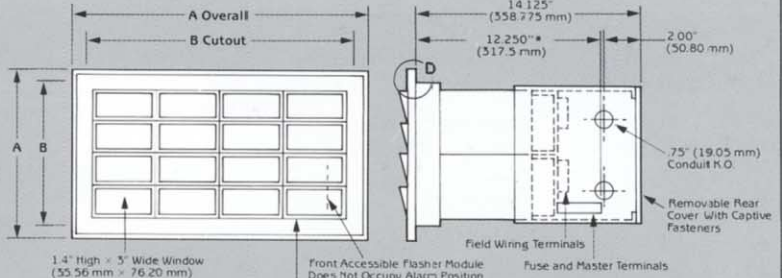

Option: Pushbutton Module Standard Position, Other Positions Optional

* Depth With Side and Rear Cover Removed
Note: Standard Finish Baked Enamel Black

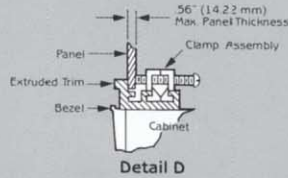

Detail D

*The integral Pushbutton Station shown is available as an option and may occupy any position in the system. Pushbutton stations will operate in conjunction with externally wired pushbuttons. The lower, right hand position also houses the Flasher/Horn Driver Module.

Number of Windows	High	Wide	A Overall		B Cutout	
			In.	mm	In.	mm
2	1	5.00	127.0	4.38	111.1	
4	2	8.50	215.9	7.88	200.0	
6	3	12.00	304.8	11.38	288.9	
8	4	15.50	393.7	14.88	377.8	
10	5	19.00	482.6	18.38	466.7	
12	6	22.50	571.5	21.88	555.6	
14	7	26.00	660.4	25.38	644.5	
16	8	29.50	749.3	28.88	733.4	
18	9	33.00	838.2	32.50	823.5	
20	10	36.50	927.1	36.00	914.4	
22	11	40.00	1016.0	39.50	1003.3	
24	12	43.50	1104.9	43.00	1092.2	

Model X11RR-2000 Relay Rack Mounting Type 19 Inch Rack Mounting – Standard 24 Inch Rack Mounting – Optional

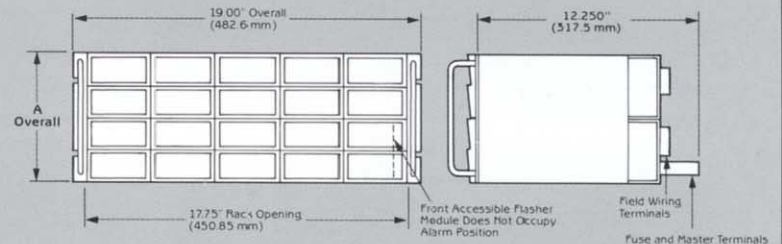

*Not limited to 8 high
**Limited to 5 wide only (19 inch, 483 mm rack)
Also available 6 wide (24 inch, 610 mm rack)

Number of Windows	High	Wide	A Overall	
			In.	mm
2	5**	3.5	88.9	
4	5	7.0	177.8	
6	5	10.5	266.7	
8*	5	14.0	355.6	

Series X11-2000 Rear Terminal Arrangement and Wiring Information

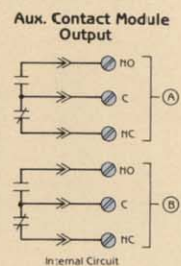
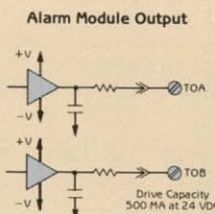
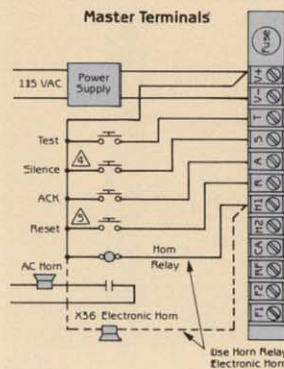
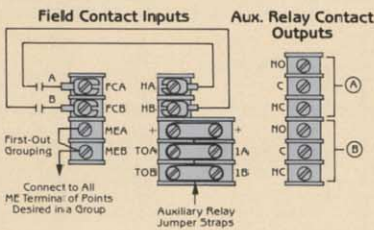

- Notes:
- CA Terminal Provides Logic Zero as Long as Any Point in the System is in Alarm
 - RF Terminal Provides an Output Pulse to Refresh a Remote Annunciator as New Points Alarm
 - F1,F2 Flasher Sync Connection for Multichassis Applications
 - Silence Pushbutton Optional, Not Required for Operation
 - Reset Pushbutton Only Used for FSA Sequence

TRIALARM SERIES

Model X11-3000 Flush Mounting Type for Control Panels Nameplate Size .86" (22 mm) × 3.00" (76 mm)

These systems are interchangeable.

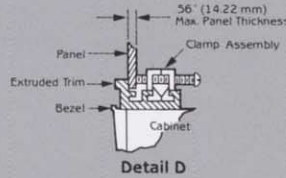
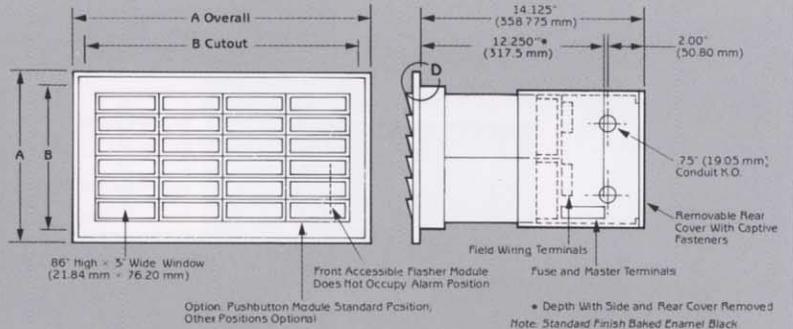
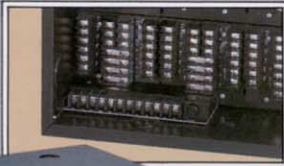

*Pushbutton Stations

*The integral Pushbutton Station shown is available as an option and may occupy any position in the system. Pushbutton stations will operate in conjunction with externally wired pushbuttons. The lower, right hand position also houses the Flasher/Horn Driver Module.

Number of Windows		A Overall		B Cutout	
High	Wide	In.	mm	In.	mm
3	1	5.00	127.0	4.38	111.1
6	2	8.50	215.9	7.88	200.0
9	3	12.00	304.8	11.38	288.9
12	4	15.50	393.7	14.88	377.8
15	5	19.00	482.6	18.38	466.7
18	6	22.50	571.5	21.88	555.6
21	7	26.00	660.4	25.38	644.5
24	8	29.50	749.3	28.88	733.4
27	9	33.00	838.2	32.50	825.5
30	10	36.50	927.1	36.00	914.4
33	11	40.00	1016.0	39.50	1003.3
36	12	43.50	1104.9	43.00	1092.2

Model X11RR-3000 Relay Rack Mounting Type 19 Inch Rack Mounting – Standard 24 Inch Rack Mounting – Optional

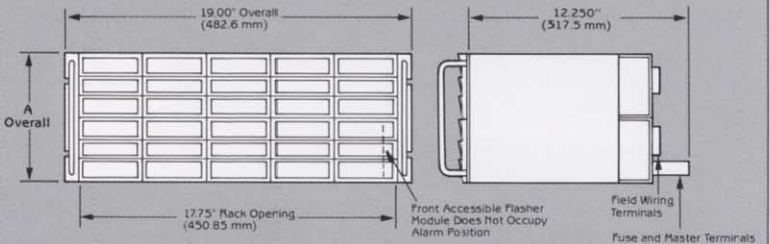
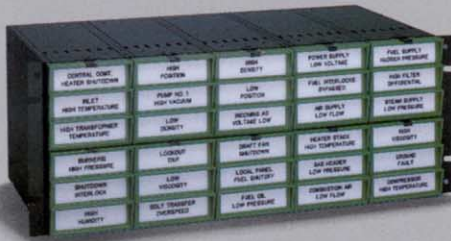

*Not limited to 8 high
**Limited to 5 wide only (19 inch, 483 mm rack)
Also available 6 wide (24 inch, 610 mm rack)

Number of Windows		A Overall	
High	Wide	In.	mm
3	5**	3.5	88.9
6	5	7.0	177.8
9	5	10.5	266.7
12*	5	14.0	355.6

Series X11-3000 Rear Terminal Arrangement and Wiring Information

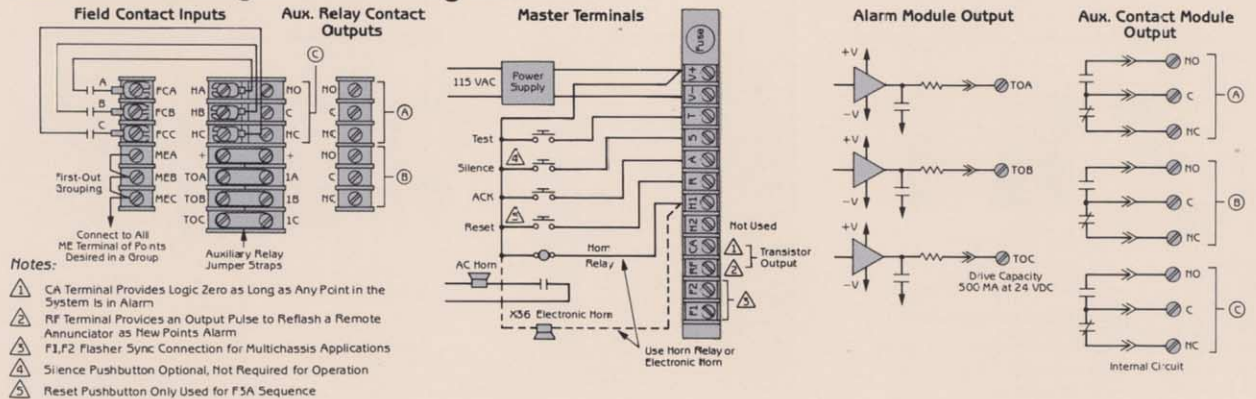

SEQUENCES

Sequence A, Automatic Reset

Sequence Features

1. Acknowledge and Test Pushbuttons.
2. Alarm Audible Device.
3. Lock-In of Momentary Alarms Until Acknowledged.
4. The Audible Device is Silenced and Flashing Stops When Acknowledged.
5. Automatic Reset of Acknowledged Alarm Indications When Process Conditions Return to Normal.
6. Operational Test.

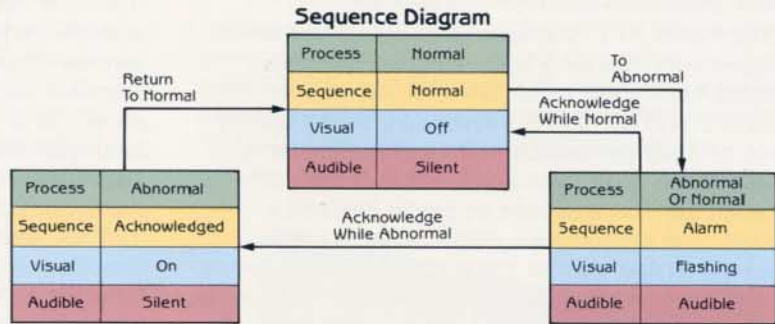

Sequence F3A, Automatic Reset First Out With First Out Flashing and Reset Pushbutton

Sequence Features

1. Acknowledge, First Out Reset, and Test Pushbuttons.
2. Alarm Audible Device.
3. Lock-In of Momentary Alarms Until Acknowledged.
4. First Out Flashing Different from Subsequent Flashing.
5. First Out Reset Pushbutton to Change the First Out Visual Indication to be the Same as Subsequent Visual Indications.
6. Automatic Reset of Acknowledged Alarm Indications When Process Conditions Return to Normal.
7. Operational Test.

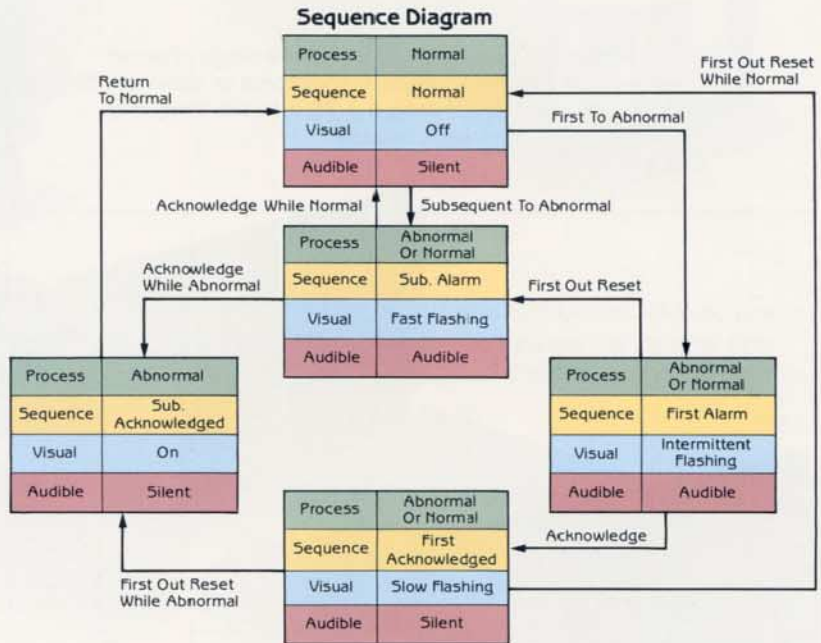

Sequence M, Manual Reset

Sequence Features

1. Acknowledge, Reset and Test Pushbuttons.
2. Alarm Audible Device.
3. Lock-In Momentary Alarms Until Acknowledged.
4. The Audible Device Is Silenced and Flashing Stops When Acknowledged.
5. Manual Reset of Acknowledged Alarm Indications After Process Conditions Return to Normal.
6. Operational Test.

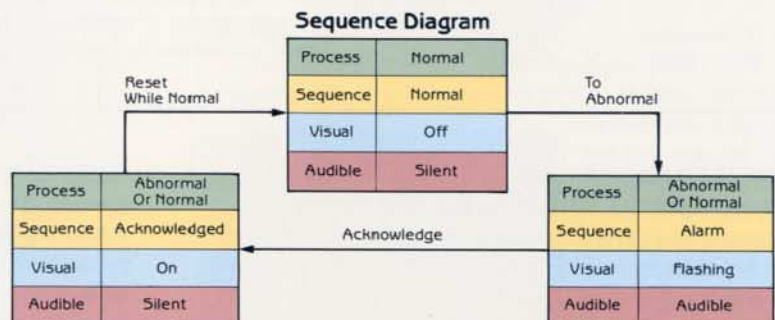

ALARM MODULES

Alarm Sequence/Display Module

The Model X11 is offered in two dual sequence configurations, allowing field selection of either the most commonly used ISA-A, or the popular first out ISA-F3 and the ISA-M sequences, selectable by means of a jumper switch setting on each alarm module. ISA-R Ring Back and ISA-A-4-5 status Indication are also available as single sequence modules. The combination display/alarm module contains a single, dual or triple alarm channel circuit with the appropriate dual lamp display constructed as a single plug-in module. The modules are removable

from the front of the system without interference with the remaining channels of the system. The window display areas are contained within Ronan's standard colored bezels, allowing multi-line engraving on single or sandwich lenses. The alarm logic may interface with a normally open or normally closed field contact. The field contacts are interrogated by the system's 24VDC logic supply, or optionally with 125VDC from a dual output power supply, if so specified. Modules are available with optical isolation and can accept 115VAC or 125VDC live field contact voltages.

Monalarm

The monalarm plug-in module features single channel alarm logic with two 3 watt incandescent or optional LED type indicators* illuminating a 2.75 inch (70 mm) high by 3 inch (76 mm) wide window.

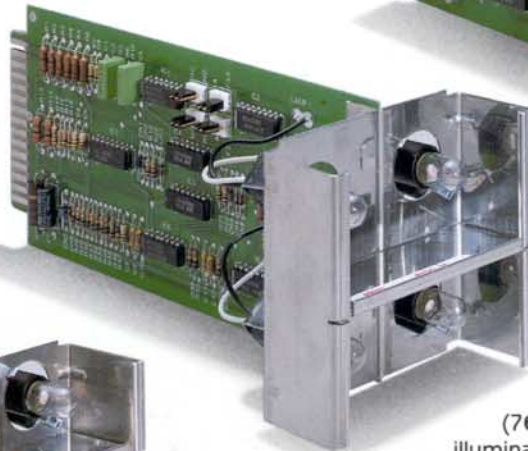

Binalarm

The two-window binalarm module contains two channels of alarm logic to display alarm conditions on two windows, sized for 1.44 inch (36 mm) high and 3 inch (76 mm) wide lenses. Each window is illuminated by two 2 watt lamps or LED type indicators.*

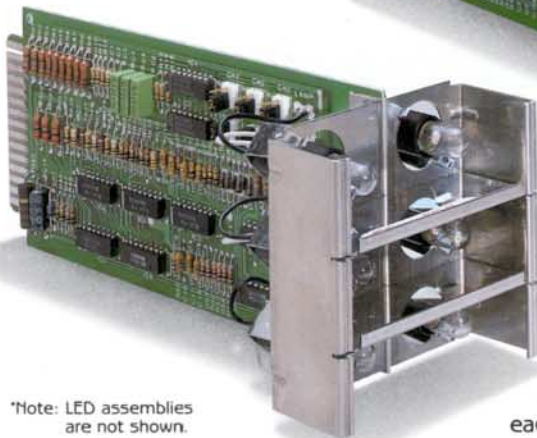

Trialarm

The trialarm module represents the highest possible density of the Model X11 Series. The three 0.86 inch (22 mm) high by 3 inch (76 mm) wide windows are illuminated by three sets of two 2 watt lamps or optional LED type indicators*, each set driven by one channel of the three channel alarm logic.

*Note: LED assemblies are not shown.

Output Features

The Model X11 System provides a common trouble alarm (CTA) output, presented on the master terminal assembly. This output drives a system's internally or remotely mounted relay to annunciate an alarm condition if any one or more points in the system are in alarm. A second output, also presented on the master terminal assembly, features a reflash

signal which allows reannunciation to a remote system of any one window going into alarm. In addition, each field contact input is repeated and presented as an output on rear terminals by way of an open collector transistor. These, per-point, outputs allow multigrouping of alarms, or are utilized to drive internal auxiliary contact repeater relays, providing a Form C contact, available on rear mounted terminals.

FLASHER, PUSHBUTTON/FLASHER MODULES

The dual frequency flashing signal generator and the pushbutton/audible alarm interface is furnished by the flasher module. The flasher is master/slave selectable to allow synchronization of flash rates in multi-system applications. The module is designed to drive up to 150 points of alarm and for convenience purposes is always located behind the lower right hand module of the system.

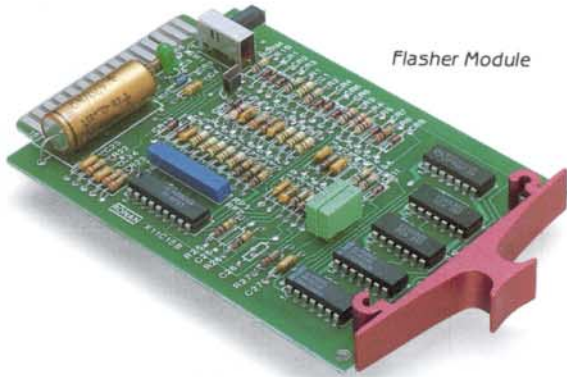

Two, three or four pushbuttons, depending on the sequence selection, may be specified. The horn driver capability of either module is sized to drive a KRP-24VDC Horn Relay or a Ronan Model X36-24 Electronic Horn. Ordering Pushbutton Module with SILENCE adds useful feature to the basic ISA sequence.

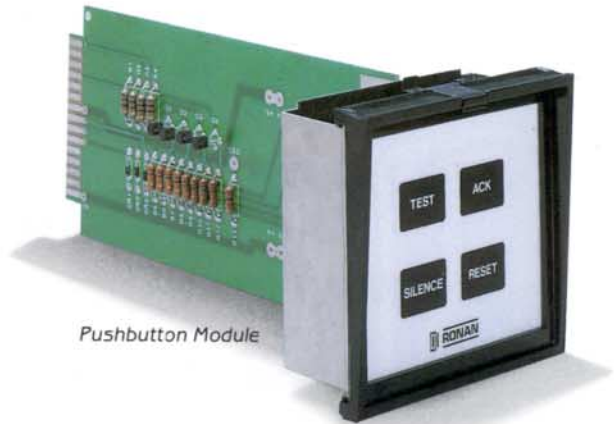

Auxiliary Contact Module

The auxiliary contact module is available with a single, dual or triple relay circuit, accommodating the window density selected. The modules plug in from the front of the system and may be purchased initially, or added later in the field. The terminals for the contact outputs are furnished on a small subpanel to be mounted on the rear terminal plate of each mechanical module. Each relay provides a Form C type contact with a rating of 3 Amp. at 28VDC, or 2 Amp. at 115VAC for the General Purpose type, and 2 Amp. at 28VDC or 1 Amp. at 115VAC for Hermetically Sealed relays.

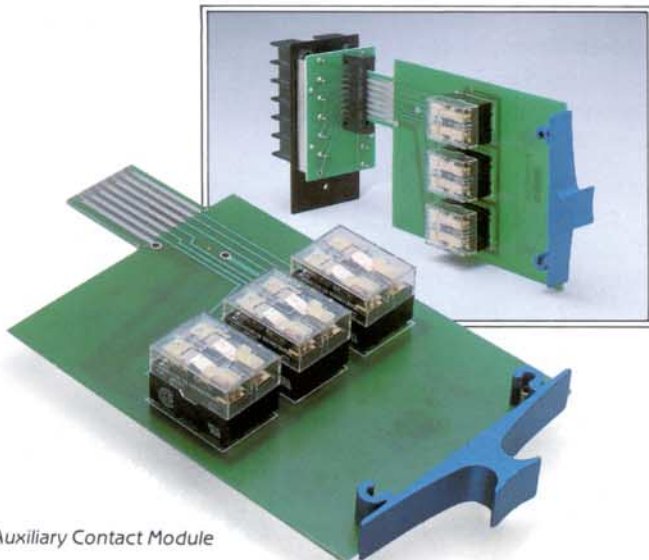

Filter Module

All remotely located pushbuttons and DC power input lines are fed to the system via integral filter modules, servicing up to 50 alarm points (36 points for 1000 Series).

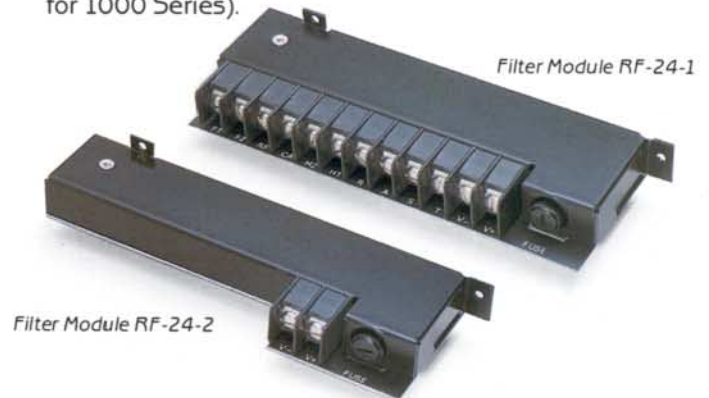

Master Terminals

The remote pushbuttons, audible alarm and power wiring are terminated at the Master Terminal Assembly located on the rear of the system's chassis. Polarity protection, to prevent reverse power hook-up, and a system's fuse, are an integral part of the Master Terminal Assembly.



NAMEPLATE ENGRAVINGS



Monalarm Series 1000 — Model WB1-()*







Binalarm Series 2000 — Model WB2-()*



Trialarm Series 3000 — Model WB3-()*

Bezel Colors Available:

	Black (0)		Green (5)		Grey (8)
	White (9)		Yellow (4)		Blue (6)
	Red (2)		Brown (1)		

*Color Code
Typical Bezel Ordering Information WB3-(0) (Black Bezel for Trialarm Series)

System Color Coding

Display and Nameplates

Ronan's Window Annunciator may be color coded by plant or process function with colored bezels and solid color or sandwich type nameplates.

Bezels

The Bezels are available in eight (8) colors without additional cost, allowing very distinct differentiation between groups of internal system's function, e.g., same sequence, first out groups, common alarm groups, etc., or plant and process groups of similar functions.

Colored Nameplates

The Nameplates may be supplied in five distinct standard colors to identify functions such as fire alarm, shutdown, etc.

Sandwich Nameplates

The Sandwich Nameplates, an option exclusive to the Ronan Visual Annunciator, are generally supplied with white front lens and colored back lens. This lens combination displays all windows white in non-lit status, changing to the selected color in OFF-Normal condition.

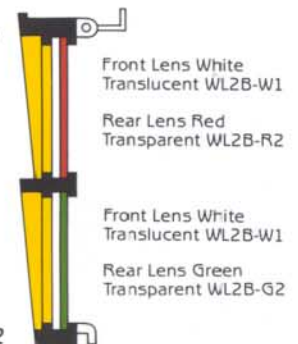

Typical Bezel DB2

POWER SUPPLIES/INVERTERS

Your Alarm System may be powered from 115VAC 60 Hz, 220VAC 50 Hz or 125VDC sources by using a power supply or inverter, generating a

nominal 24VDC unregulated voltage (18-28VDC) for the logic and lamps, and 24VDC or 125VDC for field contact interrogation.

Power Requirement

To specify the correct power supply, count the number of active and future alarm modules you would like to power from the supply. Calculate the total requirement as follows:

Total Watts = No. of Alarm Modules × Factor (F)

F = 7.5 for X11-1000

F = 10.5 for X11-2000

F = 15.5 for X11-3000

F includes power requirements for Auxiliary Contact Relays (less 1 Watt if relays are not required).

Match the total wattage with the next higher power rating of the listed Power Supply or Inverter.

DC — DC Converters

Model — Power Failure, Circuit Breaker, Power ON Light, Diode Gated

125 - 24/125 - 150SCP
 125 - 24/125 - 300SCP
 125 - 24/125 - 600SCP
 48 - 24/125 - 150SCP
 48 - 24/125 - 300SCP
 48 - 24/125 - 600SCP

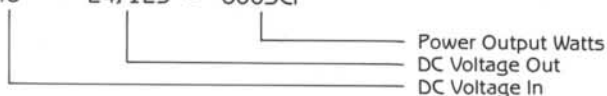

AC — DC Power Supplies

115 - 24 - 125
 115 - 24 - 250
 115 - 24 - 375
 115 - 24 - 500
 115 - 24 - 750
 220 - 24 - 125
 220 - 24 - 250
 220 - 24 - 375
 220 - 24 - 500
 220 - 24 - 750
 115 - 24/125 - 125
 115 - 24/125 - 250
 115 - 24/125 - 375
 115 - 24/125 - 500
 115 - 24/125 - 750
 115 - 24 - 250DA
 115 - 24 - 375DA
 115 - 24 - 500DA
 115 - 24 - 750DA

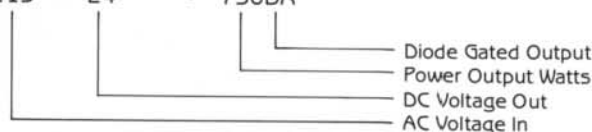

General Specifications

Systems Voltage:

Logic, Field Contact, Lamps: 24VDC ±20%

Field Contact: 125VDC ±20% Optional

Power Sources:

Systems External Power Supplies or Inverters Available for: 120VAC ±20% 60Hz; 240VAC ±20% 50/60Hz; 24, 48 or 125VDC ±20%

Temperature Range:

Storage: -40° to +85°C (-40° to +185°F)

Operating: -40° to +60°C (-40° to +185°F) with incandescent lamps; 0° to +60°C (32° to +140°F) with LED type indicators.

Inputs:

Contact: Normally Open, Normally Closed; Systems Internal Interrogation Voltage 24VDC Standard, 48 or 125VDC Opt.

Response Time:

10 msec Nominal

Surge Withstand Capability (SWC):

All Logic Tested to: IEEE 472 — 1974 and ANSI/IEEE C37-90 — 1978

Outputs:

Light: Fast Flash, Slow Flash, Steady On, Intermittent Fast Flash

Alarm: Single Audible

Auxiliary Relay: Form C, Normally Not Energized

Hermetically Sealed: Rating 2 Amp. 28VDC, 1 Amp. 115VAC

General Purpose: Rating 3 Amp. 28VDC, 2 Amp. 115VAC

Audible-, Retransmit-, Common Trouble Alarm Relay: DPDT, Rating 10 Amp. 28VDC, 10 Amp. 125VAC

Controls:

Integral or Remote Silence, Acknowledge, Reset, Test: Momentary Pushbutton, Single Pole, Normally Open

Systems Size:

Multiple of Cabinet Module: 3.5" (89 mm) × 3.5" (89 mm)

Systems Weight:

Per Cabinet Module: 1.5 lbs. (.69 kg) Not Including Power Supply

ACCESSORIES — PUSHBUTTONS/HORNS

Pushbuttons



General Purpose

Type	Contact	Rating
202B Oil Tight	1NO 1NC	
203B Pushbutton	2 NO 2NC	24VDC, 5 Amp.
2025 Oil Tight	1NO 1NC	125VDC, 2 Amp.
2035 Switch	2NO 2NC	

Mercury Type — Class I Div. 2 Locations

Type	Contact	Rating
X13P () () P.B.	Up to	24VDC, 10 Amp.
X135 () () Switch	4NO or NC	125VDC, 5 Amp.

NO or NC
 Number of Contacts

Horn Relays

General Purpose

Model	Voltage	Contact Rating
KRP-24VDC	24VDC	10 Amp.

Hermetically Sealed — Class I Div. 2

Model	Voltage	Contact Rating
KR7272	24VDC	10 Amp.



Socket

Model 146-103 to be mounted by customer.

Power Supplies

(For Details see Page 13)

Water Tight Doors

- () () X11-1022M12, Nema 12
- () () X11-1022N4, Nema 4

Cabinet Modules High
 Cabinet Modules Wide

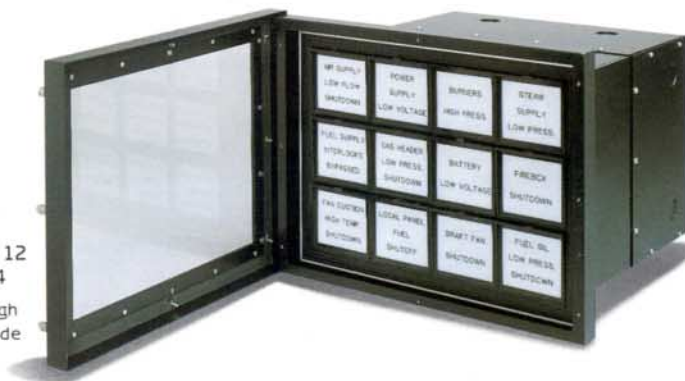

Horns — Vibrating Type

Model	Description
350N-115 VAC	Class I, Division 2 or General Purpose
450N-(Voltage)	General Purpose — Specify 125VDC or 24VDC
350W-115 VAC	Class I, Division 2 or General Purpose
450W-(Voltage)	General Purpose — Specify 125VDC or 25VDC
350F-115 VAC	Class I, Division 2 or General Purpose
450F-(Voltage)	General Purpose — Specify 125VDC or 24VDC
351N-115 VAC	Class I, Division 2 or General Purpose
451N-(Voltage)	General Purpose — Specify 125VDC or 24VDC
351W-115 VAC	Class I, Division 2 or General Purpose
451W-(Voltage)	General Purpose — Specify 125VDC or 24VDC
8140-115 VAC	Explosion Proof Class I, Division 1
8141-(Voltage)	Explosion Proof Class I, Division 1, 125VDC or 24VDC
300XB-(Voltage)	Explosion Proof Class I, Division 1, 24VAC, 125VDC or 24VDC
8150-115 VAC	Explosion Proof Class I, Division 1
8151-24VDC	Explosion Proof Class I, Division 1

*Choose voltage from description column.



Bells

Model	Description
504N-115 VAC	General Purpose, 4 Inch Diameter
506N-115 VAC	General Purpose, 6 Inch Diameter
510N-115 VAC	General Purpose, 10 Inch Diameter
604N-125 VDC	General Purpose, 4 Inch Diameter
606N-125VDC	General Purpose, 6 Inch Diameter
610N-125VDC	General Purpose, 10 Inch Diameter
504W-115 VAC	Weatherproof, 4 Inch Diameter
506W-115 VAC	Weatherproof, 6 Inch Diameter
510W-115 VAC	Weatherproof, 10 Inch Diameter
604W-125VDC	Weatherproof, 4 Inch Diameter
606W-125VDC	Weatherproof, 6 Inch Diameter
610W-125VDC	Weatherproof, 10 Inch Diameter



Chimes — Single Stroke

- X12-1128-115VAC
- X12-1128-125VDC
- X12-1128-24VDC



Horns — Electronic

- X36-24VDC
- X36-48VDC
- X36-115VAC
- Sonalert-24VDC
- Sonalert-115VAC

TYPICAL ORDERING INFORMATION

X11 Series Window Model

QTY

Configuration/Enclosures

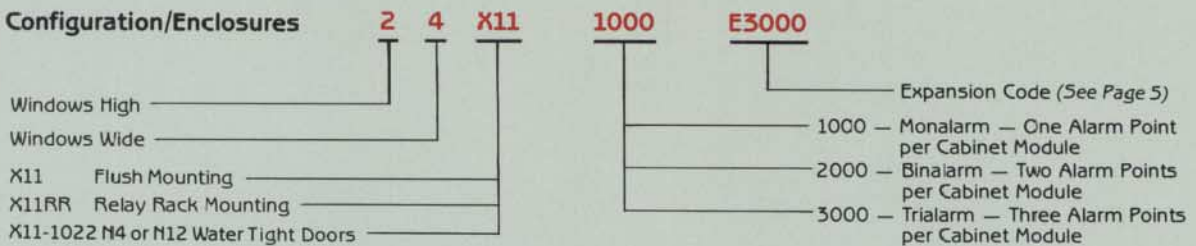

System Detail

Cabinet Modules

Alarm/Display Modules

- X11/1-F3A/A Monalarm, Single Alarm Point and Display Module
- X11/1-M/A Monalarm, Single Alarm Point and Display Module
- X11/2-F3A/A Binalarm, Dual Alarm Points and Display Module
- X11/2-M/A Binalarm, Dual Alarm Points and Display Module
- X11/3-F3A/A Trialarm, Three Alarm Points and Display Module
- X11/3-M/A Trialarm, Three Alarm Points and Display Module

Support Modules

- X11-FHD Flasher/Horn Driver Integral (Order One Per 150 Points)
 - X11-PB2 Pushbutton Module (Ack, Test) Occupies One Cabinet Module *
 - X11-PB3A Pushbutton Module (Ack, Reset, Test) Occupies One Cabinet Module *
 - X11-PB3B Pushbutton Module (Sil, Ack, Test) Occupies One Cabinet Module *
 - X11-PB4 Pushbutton Module (Sil, Ack, Reset, Test) Occupies One Cabinet Module *
 - X11-RF-24-1 Filter Module (Order One for Each 10 Amperes Input Power)
 - X11-RF-24-2 Filter Module (Order One for Each Additional 10 Amperes Input Power)
- *Pushbutton Module Will Be Located in the Lower Right Corner (If Not Otherwise Specified)

Auxiliary Function Modules

- X11/1-Aux-() Single Point Auxiliary Contact Module (See Page 11)
 - X11/2-Aux-() Dual Points Auxiliary Contact Module (See Page 11)
 - X11/3-Aux-() Triple Points Auxiliary Contact Module (See Page 11)
- GP or H5

Accessories

- 202B Pushbutton, Externally Mounted - General Purpose (See Page 14)
- X13P1NO Pushbutton, Externally Mounted - Class I, Div. 2 (See Page 14)
- KRP-24 Horn Relay - General Purpose Type (See Page 14)
- KR-7272 Horn Relay - Class I, Div. 2 Type (See Page 14)
- 146-103 Socket for Horn Relay for External Mounting
- Horns (See Page 14)
- Bells (See Page 14)
- Chimes (See Page 14)
- Power Supply/Inverter (Order as Required) (See Page 13)

Options

- Gold Plated Printed Circuit Connectors
- Fungus Proof Coating
- Sandwich Lenses (Specify Colors)
- Colored Lenses (Specify Colors)
- System Air Purge



**RONAN ENGINEERING
COMPANY**

P.O. Box 1275
21200 Oxnard Street
Woodland Hills
California 91367 U.S.A.
(818) 883-5211
FAX (818) 992-6435

**RONAN ENGINEERING
LIMITED U.K.**

1 Tilley Road
Crowther Industrial Estate
Washington, Tyne and Wear
United Kingdom, NE38-OEA
(191) 416-1689
FAX (191) 416-5856

**RONAN ENGINEERING
LIMITED**

32 Bermondsey Road
Toronto, Ontario
Canada M4B1Z5
(416) 752-0310
FAX (416) 752-8072

**RONAN ENGINEERING
(AUST.) PTY. LTD.**

Unit 10, 8 Leighton Place
Hornsby, N.S.W. 2077
Australia
(02) 477-7344
FAX (02) 477-6151